

# Contents

01	Standards & Specification
04	Dimensions of Ductile Iron Pipes
08	Dimensions of Ductile Iron Fittings
29	Pipe Jointing & Assembly
32	Pipe Handling Recommendations
33	Pipe Installation & Joint Assembly Method
34	Corrosion Protection
35	Pipeline PE Sleeving Installation

SHIN NAN CASTING  
FACTORY CO., LTD



## DUCTILE IRON PIPES & FITTINGS



Shin Nan ductile iron pipes and fittings for water and sewerage systems are manufactured according to EN 545 / EN 598 / EN969 / ISO 2531 and under the quality control system of ISO 9001 for quality assurance. The standard nominal sizes DN of pipes to fittings are from 80 mm to 2000 mm. Every pipe and fitting are strictly subjected to hydrostatic pressure tests of the relevant standards.

## ○ Standards

<b>ISO 2531</b>	Ductile iron pipes, fittings and accessories for pressure pipelines
<b>ISO 7186</b>	Ductile iron pipes, fittings, accessories for sewage pipelines
<b>BS EN 545</b>	Ductile iron pipes, fittings, accessories and their joints for water pipelines
<b>BS EN 598</b>	Ductile iron pipes, fittings, accessories and their joints for sewerage pipelines
<b>BS EN 969</b>	Ductile iron pipes, fittings, accessories and their joints for gas pipelines (DN 80 ~ 600mm)
<b>BS EN 7892</b>	Specification for coats on cement mortar lined ductile iron pipes and fittings
<b>ISO 8179-1</b>	Ductile iron pipes-External Zinc-based coating, Part1 : Metallic Zinc with finishing layer
<b>ISO 8179-2</b>	Ductile iron pipes-External Zinc-based coating, Zinc rich paint with finishing layer
<b>ISO 4179</b>	Ductile iron pipes and fittings for pressure and non-pressure pipelines-cement mortar linings.
<b>BS EN 6920</b>	Suitability of non-metallic products for use in contact with water intended for human consumption with regard to their effect on the quality of water. Methods of test.

## ○ Pipes

- ▶ Standard pipes with flexible joints shall be available for C-class, and also available for class K9, class K7, K10 & K12.
- ▶ Standard pipes with flanges screwed or cast-on shall be class K12.
- ▶ Standard pipes with flanges welded-on shall be class K9.
- ▶ The standard lengths and thickness of pipes are shown in our catalogue. Lengths of pipes other than those shown may be supplied by agreement between the purchaser and the manufacturer and shall be deemed to comply with the requirements of this specification.
- ▶ In the case of centrifugally cast pipes, the increase or decrease, in the thickness of the pipe wall shall be obtained variation of the internal diameter only.

## ○ Fittings

- ▶ All standard fittings shall be class K12.

## ○ Types of Joints

### > Flexible Joints

- ▶ "Push on" "T" type (Tyton Joint) are available for pipes & fittings of the range DN 80 ~ DN 2400.
- ▶ "Mechanical" "K" type (Bolted-Gland Joint) are available for pipes and fittings of the range DN 80 ~ DN 2600.

Note:

Standard rubber gaskets for potable water comply with BS 2494:1990 "W" type (water), EN 681-1, ISO 4633 & BS 6920.

Rubber gaskets for sewerage application are nitrile or synthetic rubber comply with EN 598.

Rubber gaskets for gas pipeline in compliance to ISO 6447.

### > Flange Joints

- ▶ Dimensional details of flanges designated PN 10, PN 16, PN 25 and PN 40 are produced in accordance with ISO 2531 / ISO 7186 / EN 545 / EN 598 / EN 969. Flanges shown in our specification are dimensionally compatible with the corresponding flanges BS 4504.
- ▶ PN 16 flanges are supplied as standard for pipes and fittings of the range DN 80 ~ DN 2000. PN 10, PN 25 and PN 40 flanges are also available upon request.

## Pressure & Temperature Ratings

- Works proof and leak tightness pressures for K class

DN (Nominal size) mm	Pipes		Fittings
	bar K<9	bar K ≥ 9	bar
80 ~ 300	0.5 (K+1) <sup>2</sup>	50	25
350 ~ 600	0.5 K <sup>2</sup>	40	16
700 ~ 1200	0.5 (K-1) <sup>2</sup>	32	10
1400 ~ 2000	0.5 (K-2) <sup>2</sup>	25	10

- The nominal pressure rating are applicable to the temperature range -10°C to 80°C; the purchasers should be consulted with the manufacturers where pressure-temperature conditions are out of this range.

## Angular Deflection & Straight Draw of "Push-in" Type Flexible Joint (Tyton Joint)

DN (Nominal size) mm	Allowable Angular Deflection	Allowable Straight Draw Without Deflection
80 ~ 300	5°	38 mm
350 ~ 600	4°	38 mm
700 ~ 800	4°	56 mm
900 ~ 1200	4°	70 mm
1400 ~ 1600	4°	95 mm
1800 ~ 2000	1.5°	105 mm

## Tolerances on Dimensions

*Dimensions in mm*

Tolerances on Wall Thickness (e) for K class					
Type of Casting			Tolerance		
Pipes centrifugally cast			- (1.3 + 0.001 DN)		
Pipes do not centrifugally cast and fittings			- (2.3 + 0.001 DN)		
Tolerances on Lengths					
Type of Casting			Tolerance		
Socket and spigot pipes (full length or shortened)			+ 70 , -30		
Fitting for socketed joint			± 20		
Pipes and Fitting for flanged joint			± 10		
Internal Diameter					
DN			Limit Deviation		
400-1000			- 10		
1100-2000			- 0.01 DN		
Tolerances on External Diameters (DE)					
DN	DE	Tolerance	DN	DE	Tolerance
80	98	+1 / -2.7	900	945	+1 / -4.8
100	118	+1 / -2.8	1000	1048	+1 / -5.0
150	170	+1 / -2.9	1100	1152	+1 / -6.0
200	222	+1 / -3.0	1200	1255	+1 / -5.8
250	274	+1 / -3.1	1400	1462	+1 / -6.6
300	326	+1 / -3.3	1500	1565	+1 / -7.0
350	378	+1 / -3.4	1600	1668	+1 / -7.4
400	429	+1 / -3.5	1800	1875	+1 / -8.2
450	480	+1 / -3.6	2000	2082	+1 / -9.0
500	532	+1 / -3.8			
600	635	+1 / -4.0			
700	738	+1 / -4.3			
800	842	+1 / -4.5			
Straightness of Pipes					
Pipes shall be straight with a maximum deviation of 0.125% of their length.					

## Mechanical Properties

Pipes		Fittings
Tensile	420 N / mm <sup>2</sup> (MPa) min.	
Elongation	DN ≤ 1000	10% Min.
	DN ≥ 1100	7% Min.
Hardness	HB 230 max.	
		HB 250 max.

## Coatings & Linings

	Pipes	Fittings
External	<p><b>Potable Water:</b></p> <ul style="list-style-type: none"> <li>Unless otherwise specified by the purchaser, all pipes are coated externally zinc coating with covered by a finishing layer of Bituminous paint in accordance with BS EN 545 /ISO 2531 and ISO 8179.</li> <li>Bituminous paint complies with BS 4147 : 1980 type I grade C or</li> </ul> <p><b>Sewerage:</b></p> <ul style="list-style-type: none"> <li>BS EN 598 / ISO 7186</li> <li>Unless otherwise specified by the purchaser all pipes are coated externally with zinc coating covered by a finish layer of reddish epoxy paint.</li> </ul> <p><b>Gas:</b></p> <ul style="list-style-type: none"> <li>Bitumen or synthetic resin base paint coating.</li> </ul>	<p><b>Potable Water:</b></p> <ul style="list-style-type: none"> <li>Unless otherwise specified by the purchaser, all fittings are coated externally with zinc coating covered by a finishing layer of bituminous paint in accordance with BS EN 545 /ISO 2531 and ISO 8179.</li> <li>Bituminous paint complies with BS 4147 : 1980 type I grade C or</li> <li>Fusion Bonded Epoxy, Liquid applied Epoxy coating are also available upon request.</li> </ul> <p><b>Sewerage:</b></p> <ul style="list-style-type: none"> <li>BS EN 598 / ISO 7186</li> <li>Unless otherwise specified by the purchaser all fittings are coated externally with zinc coating covered by a finish layer of reddish epoxy paint.</li> </ul> <p><b>Gas:</b></p> <ul style="list-style-type: none"> <li>Bitumen or synthetic resin base paint coating.</li> </ul>
Internal	<p><b>Potable Water:</b></p> <ul style="list-style-type: none"> <li>Unless otherwise specified by the purchaser, all pipes are sulphate-resistant cement lined to ISO 4179.</li> <li>Liquid epoxy seal coating is also available upon request and comply to BS 6920/ BS 7892.</li> <li>Fusion Bonded Epoxy is available upon request and comply to BS 14901.</li> </ul> <p><b>Sewerage:</b></p> <ul style="list-style-type: none"> <li>Unless otherwise specified by the purchaser all pipes are high alumina cement lined comply to EN 598 / ISO 7186.</li> <li>Liquid epoxy seal coating and Fusion Bonded Epoxy are also available upon request and comply to EN 598 / ISO 7186 for sewerage application or corrosive resistant purposes.</li> </ul> <p><b>Gas:</b></p> <ul style="list-style-type: none"> <li>Bitumen or synthetic resin base paint coating.</li> </ul>	<p><b>Potable Water:</b></p> <ul style="list-style-type: none"> <li>Unless otherwise specified by the purchaser, Fusion Bonded Epoxy, Liquid applied Epoxy coating are also available upon request and comply to BS 6920/ BS 14901 .</li> </ul> <p><b>Sewerage:</b></p> <ul style="list-style-type: none"> <li>Unless otherwise specified by the purchaser all fittings are internally lined with Epoxy for corrosive resistant purposes.</li> </ul> <p><b>Gas:</b></p> <ul style="list-style-type: none"> <li>Bitumen or synthetic resin base paint coating.</li> </ul>

Limit deviation in mm

Sulphate-Resistant Cement Mortar Lining BS EN 545 : 2002 / 598-2007+AI:2009			
Nominal Size DN	Thickness		Maximum crack width and maximum radial displacement
	Nominal value	Individual minimum value	
80 ~ 300	4	-1.5	0.4
350 ~ 600	5	-2.0	0.5
700 ~ 1200	6	-2.5	0.6
1400 ~ 2000	9	-3.0	0.8

★ Purchaser can consult with the manufacturer about the best choice of external coatings and internal linings to be used.

➔ Push On "T" Type Flexible Joint (Tyton) Socket & Spigot Pipe (BS/EN 545 : 2010)



Dimensions of pipes thickness

Unit : mm

Nominal size	External diameter mm		Pressure class	Minimum wall thickness e mm						
	Nominal	Limit deviations		class 20	class 25	class 30	class40	class 50	class 64	class 100
80	98	+1/-2.7	40				3.0	3.5	4.0	4.7
100	118	+1/-2.8	40				3.0	3.5	4.0	4.7
125	144	+1/-2.8	40				3.0	3.5	4.0	5.0
150	170	+1/-2.9	40				3.0	3.5	4.0	5.9
200	222	+1/-3.0	40				3.1	3.9	5.0	7.7
250	274	+1/-3.1	40				3.9	4.8	6.1	9.5
300	326	+1/-3.3	40				4.6	5.7	7.3	11.2
350	378	+1/-3.4	30			4.7	5.3	6.6	8.5	13.0
400	429	+1/-3.5	30			4.8	6.0	7.5	9.6	14.8
450	480	+1/-3.6	30			5.1	6.8	8.4	10.7	16.6
500	532	+1/-3.8	30			5.6	7.5	9.3	11.9	18.3
600	635	+1/-4.0	30			6.7	8.9	11.1	14.2	21.9
700	738	+1/-4.3	25		6.8	7.8	10.4	13.0	16.5	
800	842	+1/-4.5	25		7.5	8.9	11.9	14.8	18.8	
900	945	+1/-4.8	25		8.4	10.0	13.3	16.6		
1000	1048	+1/-5.0	25		9.3	11.1	14.8	18.4		
1100	1152	+1/-6.0	25	8.2	10.2	12.2	16.2	20.2		
1200	1255	+1/-5.8	25	8.9	11.1	13.3	17.7	22.0		
1400	1462	+1/-6.6	25	10.4	12.9	15.5				
1500	1565	+1/-7.0	25	11.1	13.9	16.6				
1600	1668	+1/-7.4	25	11.9	14.8	17.7				
1800	1875	+1/-8.2	25	13.3	16.6	19.9				
2000	2082	+1/-9.0	25	14.8	18.4	22.1				

Note :

1. The bold figures indicate the standard products which are suitable for most applications. Grey boxes represent products which are outside the scope of this standard.
2. For smaller DN, the minimum pipe wall thickness is governed by a combination of manufacturing constraints, structural performance and installation and handling requirements.
3. Pressure classes between 50 and 100 may be supplied by interpolation on request.



➔ Push On "T" Type Flexible Joint (Tyton) Socket & Spigot Pipe  
Class K9 / K12



Unit : mm

Nominal size	Thickness				Outside diameter	Nominal laying length
	Unlined pipe		Cement lining			
DN	e		e'		DE	L
	K9	K12	EN	ISO		
80	6.0	7.0	4	3	98	6000
100	6.0	7.2	4	3	118	6000
150	6.0	7.8	4	3	170	6000
200	6.3	8.4	4	3	222	6000
250	6.8	9.0	4	3	274	6000
300	7.2	9.6	4	3	326	6000
350	7.7	10.2	5	5	378	6000
400	8.1	10.8	5	5	429	6000
450	8.6	11.4	5	5	480	6000
500	9.0	12.0	5	5	532	6000
600	9.9	13.2	5	5	635	6000
700	10.8	14.4	6	6	738	6000
800	11.7	15.6	6	6	842	6000
900	12.6	16.8	6	6	945	6000
1000	13.5	18.0	6	6	1048	6000
1100	14.4	19.2	6	6	1152	6000
1200	15.3	20.4	6	6	1255	6000
1400	17.1	22.8	9	9	1462	6000
1500	18.0	24.0	9	9	1565	6000
1600	18.9	25.2	9	9	1668	6000
1800	20.7	27.6	9	9	1875	6000
2000	22.5	30.0	9	9	2082	6000



## ➔ Flanged Pipes

Flanged pipes with screwed-on flanges.  
K9 or K12  
DN 80 ~ DN 600 mm  
 $L, L_1$ , to be specified

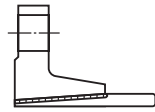
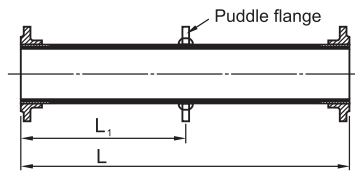

Flanged pipes with cast-on flanges.  
K12  
DN 80 ~ DN 2000 mm  
 $L \leq 2000$  mm  
 $L, L_1$ , to be specified

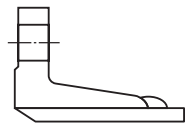
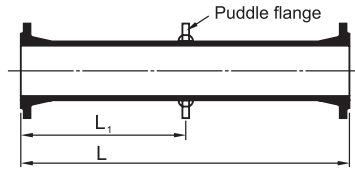

Flanged pipes with welded-on flanges.  
K9  
DN 80 ~ DN 2000 mm  
 $L, L_1$ , to be specified

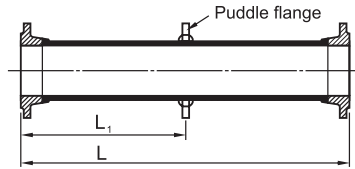

Unit : mm

Nominal size	Body	
	K9	K12
DN	e	e
80	6.0	7.0
100	6.0	7.2
150	6.0	7.8
200	6.3	8.4
250	6.8	9.0
300	7.2	9.6
350	7.7	10.2
400	8.1	10.8
450	8.6	11.4
500	9.0	12.0
600	9.9	13.2
700	10.8	14.4
800	11.7	15.6
900	12.6	16.8
1000	13.5	18.0
1100	14.4	19.2
1200	15.3	20.4
1400	17.1	22.8
1600	18.9	25.2
1800	20.7	27.6
2000	22.5	30.0

### Double-Socket 90° (1/4) Bends

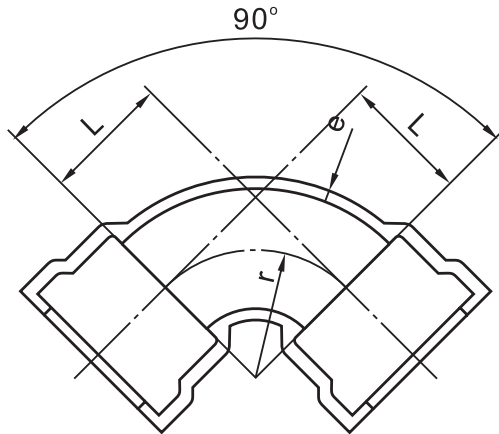

Unit : mm

Nominal size DN	e	L	r approx.
80	7.0	100	80
100	7.2	120	95
150	7.8	170	145
200	8.4	220	195
250	9.0	270	245
300	9.6	320	290
350	10.2	370	340
400	10.8	420	390
450	11.4	470	435
500	12.0	520	485
600	13.2	620	580
700	14.4	720	655
800	15.6	820	745
900	16.8	920	855
1000	18.0	1020	945
1100	19.2	1120	1065
1200	20.4	1220	1155

### Double-Socket 45° (1/8) Bends

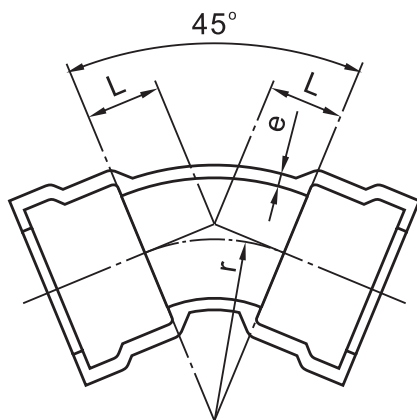

Unit : mm

Nominal size DN	e	L	r approx.
80	7.0	55	80
100	7.2	65	100
150	7.8	85	145
200	8.4	110	200
250	9.0	130	245
300	9.6	150	305
350	10.2	175	350
400	10.8	195	405
450	11.4	220	450
500	12.0	240	495
600	13.2	285	595
700	14.4	330	655
800	15.6	370	745
900	16.8	415	855
1000	18.0	460	945
1100	19.2	505	1065
1200	20.4	550	1155
1400	22.8	515	1015
1600	25.2	565	1115

➔ Double-Socket 22° 30' (1/16) Bends

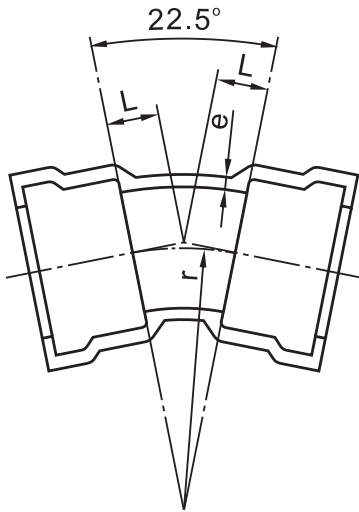

Unit : mm

Nominal size DN	e	L	r approx.
80	7.0	40	90
100	7.2	40	110
150	7.8	55	155
200	8.4	65	195
250	9.0	75	240
300	9.6	85	305
350	10.2	95	350
400	10.8	110	390
450	11.4	120	435
500	12.0	130	505
600	13.2	150	590
700	14.4	175	655
800	15.6	195	745
900	16.8	220	855
1000	18.0	240	945
1100	19.2	260	1065
1200	20.4	285	1155
1400	22.8	260	1015
1600	25.2	280	1115

➔ Double-Socket 11° 15' (1/32) Bends

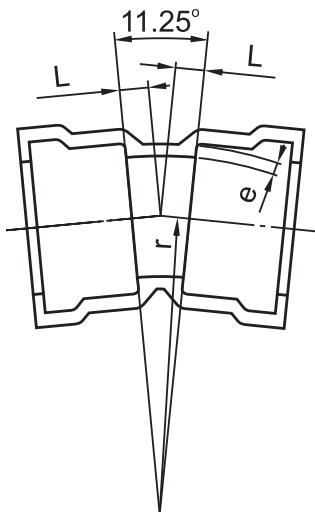

Unit : mm

Nominal size DN	e	L	r approx.
80	7.0	30	75
100	7.2	30	120
150	7.8	35	155
200	8.4	40	195
250	9.0	50	230
300	9.6	55	315
350	10.2	60	350
400	10.8	65	385
450	11.4	70	420
500	12.0	75	510
600	13.2	85	580
700	14.4	95	510
800	15.6	110	640
900	16.8	120	710
1000	18.0	130	790
1100	19.2	140	865
1200	20.4	150	965
1400	22.8	130	730
1600	25.2	140	830

➔ All Socket Tees

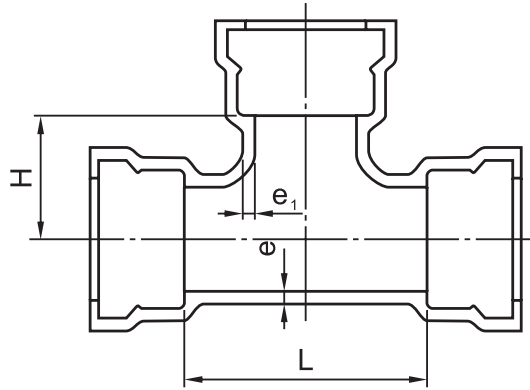

Unit : mm

Nominal size		e	e <sub>1</sub>	L	H
Body DN	Branch dn				
80	80	7.0	7.0	170	85
100	80	7.2	7.0	170	95
	100	7.2	7.2	190	95
150	80	7.8	7.0	170	120
	100	7.8	7.2	195	120
	150	7.8	7.8	255	125
200	80	8.4	7.0	175	145
	100	8.4	7.2	200	145
	150	8.4	7.8	255	150
	200	8.4	8.4	315	155
250	80	9.0	7.0	180	170
	100	9.0	7.2	200	170
	150	9.0	7.8	260	175
	200	9.0	8.4	315	180
	250	9.0	9.0	375	190
300	80	9.6	7.0	180	195
	100	9.6	7.2	205	195
	150	9.6	7.8	260	200
	200	9.6	8.4	320	205
	250	9.6	9.0	375	210
	300	9.6	9.6	435	220
350	80	10.2	7.0	185	220
	100	10.2	7.2	205	220
	150	10.2	7.8	265	225
	200	10.2	8.4	325	230
	250	10.2	9.0	380	235
	300	10.2	9.6	440	240
	350	10.2	10.2	495	250

Unit : mm

Nominal size		e	e <sub>1</sub>	L	H
Body DN	Branch dn				
400	80	10.8	7.0	185	245
	100	10.8	7.2	210	245
	150	10.8	7.8	270	250
	200	10.8	8.4	325	255
	250	10.8	9.0	385	265
	300	10.8	9.6	440	270
	350	10.8	10.2	500	275
	400	10.8	10.8	560	280
450	80	11.4	7.0	190	270
	100	11.4	7.2	215	270
	150	11.4	7.8	270	275
	200	11.4	8.4	330	280
	250	11.4	9.0	385	290
	300	11.4	9.6	445	295
	350	11.4	10.2	505	300
500	400	11.4	10.8	560	305
	450	11.4	11.4	620	310
	80	12.0	7.0	195	295
	100	12.0	7.2	215	295
	150	12.0	7.8	275	300
	200	12.0	8.4	330	305
	250	12.0	9.0	390	315
	300	12.0	9.6	450	320
500	350	12.0	10.2	505	325
	400	12.0	10.8	565	330
	450	12.0	11.4	620	335
	500	12.0	12.0	680	340

➔ All Socket Tees

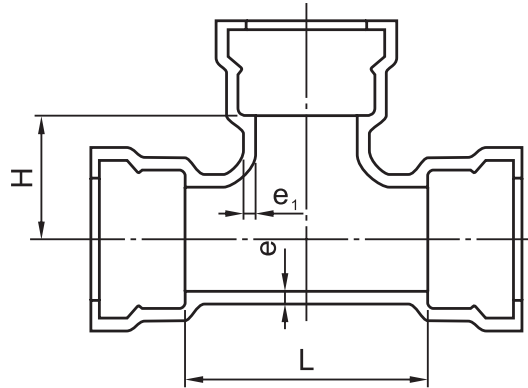

Nominal size		e	e <sub>1</sub>	L	H	Nominal size		e	e <sub>1</sub>	L	H
Body DN	Branch dn					Body DN	Branch dn				
600	80	13.2	7.0	200	345	800	150	15.6	7.8	290	450
	100	13.2	7.2	220	345		200	15.6	8.4	350	455
	150	13.2	7.8	280	350		250	15.6	9.0	410	465
	200	13.2	8.4	340	355		300	15.6	9.6	465	470
	250	13.2	9.0	395	365		350	15.6	10.2	525	475
	300	13.2	9.6	455	370		400	15.6	10.8	580	480
	350	13.2	10.2	510	375		450	15.6	11.4	640	485
	400	13.2	10.8	570	380		500	15.6	12.0	700	490
	450	13.2	11.4	630	385		600	15.6	13.2	815	500
	500	13.2	12.0	685	390		700	15.6	14.4	930	510
	600	13.2	13.2	800	400		800	15.6	15.6	1045	525
700	150	14.4	7.8	285	400	900	150	16.8	7.8	300	500
	200	14.4	8.4	345	405		200	16.8	8.4	355	505
	250	14.4	9.0	400	415		250	16.8	9.0	415	515
	300	14.4	9.6	460	420		300	16.8	9.6	470	520
	350	14.4	10.2	520	425		350	16.8	10.2	530	525
	400	14.4	10.8	575	430		400	16.8	10.8	590	530
	450	14.4	11.4	635	435		450	16.8	11.4	645	535
	500	14.4	12.0	690	440		500	16.8	12.0	705	540
	600	14.4	13.2	810	450		600	16.8	13.2	820	550
	700	14.4	14.4	925	460		700	16.8	14.4	935	560
						800	16.8	15.6	1050	575	
						900	16.8	16.8	1170	585	

Unit : mm

Unit : mm

➔ All Socket Tees

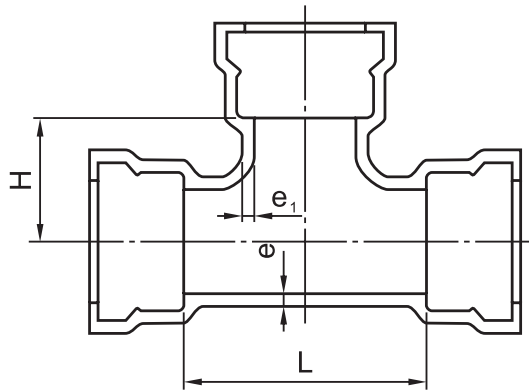

Unit : mm

Nominal size		e	e <sub>1</sub>	L	H
Body DN	Branch dn				
1200	150	20.4	7.8	315	650
	200	20.4	8.4	375	655
	250	20.4	9.0	430	665
	300	20.4	9.6	490	670
	350	20.4	10.2	550	675
	400	20.4	10.8	605	680
	450	20.4	11.4	665	685
	500	20.4	12.0	720	690
	600	20.4	13.2	840	700
	700	20.4	14.4	955	710
	800	20.4	15.6	1070	725
	900	20.4	16.8	1185	735
	1000	20.4	18.0	1300	745
	1100	20.4	19.2	1420	750
	1200	20.4	20.4	1535	765

Unit : mm

Nominal size		e	e <sub>1</sub>	L	H
Body DN	Branch dn				
1000	150	18.0	7.8	305	550
	200	18.0	8.4	360	555
	250	18.0	9.0	420	565
	300	18.0	9.6	480	570
	350	18.0	10.2	535	575
	400	18.0	10.8	595	580
	450	18.0	11.4	650	585
	500	18.0	12.0	710	590
	600	18.0	13.2	825	600
	700	18.0	14.4	940	610
	800	18.0	15.6	1060	625
	900	18.0	16.8	1175	635
	1000	18.0	18.0	1290	645
1100	150	19.2	7.8	310	600
	200	19.2	8.4	370	605
	250	19.2	9.0	425	615
	300	19.2	9.6	485	620
	350	19.2	10.2	540	625
	400	19.2	10.8	600	630
	450	19.2	11.4	660	635
	500	19.2	12.0	715	640
	600	19.2	13.2	830	650
	700	19.2	14.4	950	660
	800	19.2	15.6	1065	675
	900	19.2	16.8	1180	685
	1000	19.2	18.0	1295	695
	1100	19.2	19.2	1410	705

➔ Double-Socket Tees with Flanged Branch

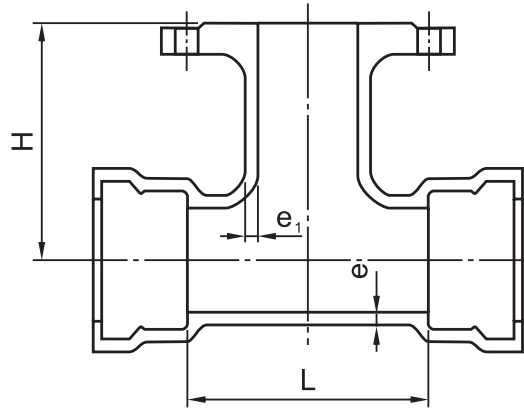

Unit : mm

Nominal size		e	e <sub>1</sub>	L	H
Body DN	Branch dn				
80	80	7.0	7.0	170	165
100	80	7.2	7.0	170	175
	100	7.2	7.2	190	180
150	80	7.8	7.0	170	205
	100	7.8	7.2	195	210
	150	7.8	7.8	255	220
200	80	8.4	7.0	175	235
	100	8.4	7.2	200	240
	150	8.4	7.8	255	250
	200	8.4	8.4	315	260
250	80	9.0	7.0	180	265
	100	9.0	7.2	200	270
	150	9.0	7.8	260	280
	200	9.0	8.4	315	290
	250	9.0	9.0	375	300
300	80	9.6	7.0	180	295
	100	9.6	7.2	205	300
	150	9.6	7.8	260	310
	200	9.6	8.4	320	320
	250	9.6	9.0	380	330
350	80	10.2	7.0	185	325
	100	10.2	7.2	205	330
	150	10.2	7.8	270	340
	200	10.2	8.4	325	350
	250	10.2	9.0	385	360
	300	10.2	9.6	440	370
	350	10.2	10.2	495	380

Unit : mm

Nominal size		e	e <sub>1</sub>	L	H
Body DN	Branch dn				
400	80	10.8	7.0	185	355
	100	10.8	7.2	210	360
	150	10.8	7.8	270	370
	200	10.8	8.4	325	380
	250	10.8	9.0	385	390
	300	10.8	9.6	440	400
	350	10.8	10.2	500	410
450	400	10.8	10.8	560	420
	80	11.4	7.0	190	385
	100	11.4	7.2	215	390
	150	11.4	7.8	270	400
	200	11.4	8.4	330	410
	250	11.4	9.0	390	420
	300	11.4	9.6	445	430
500	350	11.4	10.2	505	440
	400	11.4	10.8	560	450
	450	11.4	11.4	620	460
	80	12.0	7.0	195	415
	100	12.0	7.2	215	420
	150	12.0	7.8	275	430
	200	12.0	8.4	330	440
500	250	12.0	9.0	390	450
	300	12.0	9.6	450	460
	350	12.0	10.2	505	470
	400	12.0	10.8	565	480
	450	12.0	11.4	620	490
	500	12.0	12.0	680	500

## Double-Socket Tees with Flanged Branch

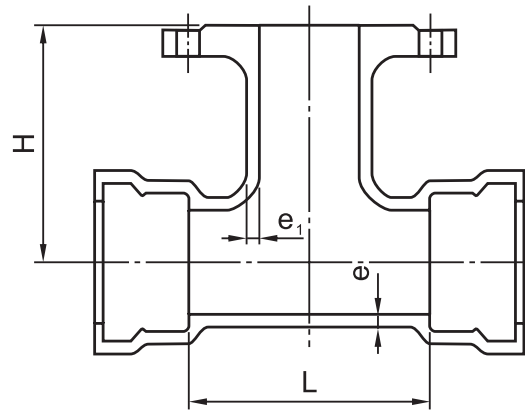

Unit : mm						Unit : mm					
Nominal size		e	e <sub>1</sub>	L	H	Nominal size		e	e <sub>1</sub>	L	H
Body DN	Branch dn					Body DN	Branch dn				
600	80	13.2	7.0	200	475	800	150	15.6	7.8	290	580
	100	13.2	7.2	220	480		200	15.6	8.4	350	585
	150	13.2	7.8	280	490		250	15.6	9.0	410	595
	200	13.2	8.4	340	500		300	15.6	9.6	465	600
	250	13.2	9.0	395	510		350	15.6	10.2	525	610
	300	13.2	9.6	455	520		400	15.6	10.8	580	615
	350	13.2	10.2	510	530		450	15.6	11.4	640	625
	400	13.2	10.8	570	540		500	15.6	12.0	700	630
	450	13.2	11.4	630	550		600	15.6	13.2	1045	645
	500	13.2	12.0	685	560		700	15.6	14.4	1045	660
600	13.2	13.2	800	580	800	15.6	15.6	1045	675		
700	150	14.4	7.8	285	520	900	150	16.8	7.8	300	640
	200	14.4	8.4	345	525		200	16.8	8.4	355	645
	250	14.4	9.0	400	535		250	16.8	9.0	415	655
	300	14.4	9.6	460	540		300	16.8	9.6	470	660
	350	14.4	10.2	520	550		350	16.8	10.2	530	670
	400	14.4	10.8	575	555		400	16.8	10.8	590	675
	450	14.4	11.4	635	565		450	16.8	11.4	645	685
	500	14.4	12.0	690	570		500	16.8	12.0	705	690
	600	14.4	13.2	810	585		600	16.8	13.2	1170	705
	700	14.4	14.4	925	600		700	16.8	14.4	1170	720
						800	16.8	15.6	1170	735	
						900	16.8	16.8	1170	750	



➔ Double-Socket Tees with Flanged Branch

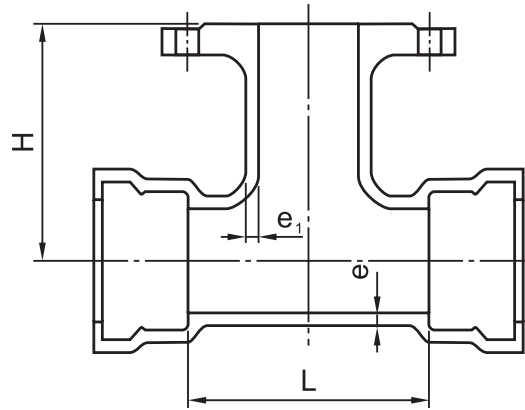

Unit : mm

Nominal size		e	e <sub>1</sub>	L	H
Body DN	Branch dn				
1000	150	18.0	7.8	305	700
	200	18.0	8.4	360	705
	250	18.0	9.0	420	715
	300	18.0	9.6	480	720
	350	18.0	10.2	535	730
	400	18.0	10.8	595	735
	450	18.0	11.4	650	745
	500	18.0	12.0	710	750
	600	18.0	13.2	1290	765
	700	18.0	14.4	1290	780
	800	18.0	15.6	1290	795
900	18.0	16.8	1290	810	
1000	18.0	18.0	1290	825	
1100	150	19.2	7.8	310	760
	200	19.2	8.4	370	765
	250	19.2	9.0	425	775
	300	19.2	9.6	485	780
	350	19.2	10.2	540	790
	400	19.2	10.8	600	795
	450	19.2	11.4	660	805
	500	19.2	12.0	715	810
	600	19.2	13.2	830	825
	700	19.2	14.4	950	840
	800	19.2	15.6	1065	855
900	19.2	16.8	1180	870	
1000	19.2	18.0	1295	885	
1100	19.2	19.2	1410	900	

Unit : mm

Nominal size		e	e <sub>1</sub>	L	H
Body DN	Branch dn				
1200	150	20.4	7.8	315	820
	200	20.4	8.4	375	825
	250	20.4	9.0	430	835
	300	20.4	9.6	490	840
	350	20.4	10.2	550	850
	400	20.4	10.8	605	855
	450	20.4	11.4	665	865
	500	20.4	12.0	720	870
	600	20.4	13.2	840	885
	700	20.4	14.4	955	900
	800	20.4	15.6	1070	915
900	20.4	16.8	1185	930	
1000	20.4	18.0	1300	945	
1100	20.4	19.2	1420	960	
1200	20.4	20.4	1535	975	

➔ All Flanged Tees

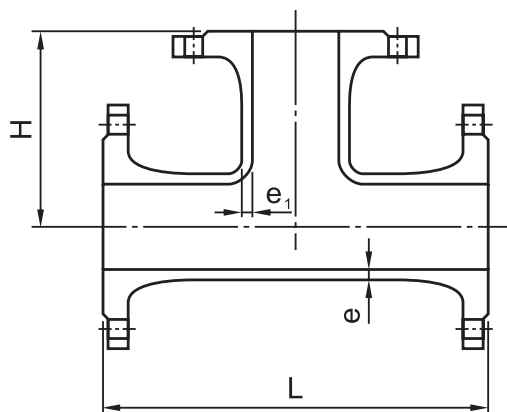

Unit : mm

Nominal size		e	e <sub>1</sub>	L	H
Body DN	Branch dn				
80	80	7.0	7.0	330	165
100	80	7.2	7.0	360	175
	100	7.2	7.2	360	180
150	80	7.8	7.0	440	205
	100	7.8	7.2	440	210
	150	7.8	7.8	440	220
200	80	8.4	7.0	520	235
	100	8.4	7.2	520	240
	150	8.4	7.8	520	250
	200	8.4	8.4	520	260
250	80	9.0	7.0	700	265
	100	9.0	7.2	700	275
	150	9.0	7.8	700	300
	200	9.0	8.4	700	325
	250	9.0	9.0	700	350
300	80	9.6	7.0	800	290
	100	9.6	7.2	800	300
	150	9.6	7.8	800	325
	200	9.6	8.4	800	350
	250	9.6	9.0	800	375
300	9.6	9.6	800	400	
350	80	10.2	7.0	850	325
	100	10.2	7.2	850	325
	150	10.2	7.8	850	325
	200	10.2	8.4	850	325
	250	10.2	9.0	850	325
	300	10.2	9.6	850	425
	350	10.2	10.2	850	425
400	80	10.8	7.0	900	350
	100	10.8	7.2	900	350
	150	10.8	7.8	900	350
	200	10.8	8.4	900	350
	250	10.8	9.0	900	350
	300	10.8	9.6	900	450
	350	10.8	10.2	900	450
400	10.8	10.8	900	450	

Unit : mm

Nominal size		e	e <sub>1</sub>	L	H
Body DN	Branch dn				
400	80	10.8	7.0	900	350
	100	10.8	7.2	900	350
	150	10.8	7.8	900	350
	200	10.8	8.4	900	350
	250	10.8	9.0	900	350
	300	10.8	9.6	900	450
	350	10.8	10.2	900	450
	400	10.8	10.8	900	450
450	80	11.4	7.0	950	375
	100	11.4	7.2	950	375
	150	11.4	7.8	950	375
	200	11.4	8.4	950	375
	250	11.4	9.0	950	375
	300	11.4	9.6	950	475
	350	11.4	10.2	950	475
	400	11.4	10.8	950	475
450	11.4	11.4	950	475	
500	80	12.0	7.0	1000	400
	100	12.0	7.2	1000	400
	150	12.0	7.8	1000	400
	200	12.0	8.4	1000	400
	250	12.0	9.0	1000	400
	300	12.0	9.6	1000	500
	350	12.0	10.2	1000	500
	400	12.0	10.8	1000	500
450	12.0	11.4	1000	500	
500	12.0	12.0	1000	500	

➔ All Flanged Tees

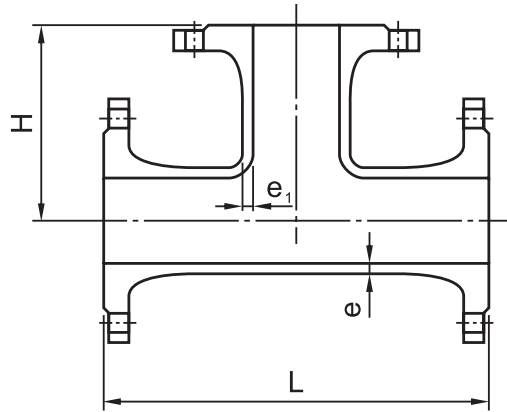

Nominal size		e	e <sub>1</sub>	L	H	Nominal size		e	e <sub>1</sub>	L	H
Body DN	Branch dn					Body DN	Branch dn				
600	80	13.2	7.0	1100	450	800	150	15.6	7.8	635	580
	100	13.2	7.2	1100	450		200	15.6	8.4	690	585
	150	13.2	7.8	1100	450		250	15.6	9.0	745	595
	200	13.2	8.4	1100	450		300	15.6	9.6	800	600
	250	13.2	9.0	1100	450		350	15.6	10.2	855	610
	300	13.2	9.6	1100	550		400	15.6	10.8	910	615
	350	13.2	10.2	1100	550		450	15.6	11.4	965	625
	400	13.2	10.8	1100	550		500	15.6	12.0	1020	630
	450	13.2	11.4	1100	550		600	15.6	13.2	1350	645
	500	13.2	12.0	1100	550		700	15.6	14.4	1350	660
600	13.2	13.2	1100	550	800	15.6	15.6	1350	675		
700	150	14.4	7.8	595	520	900	150	16.8	7.8	675	640
	200	14.4	8.4	650	525		200	16.8	8.4	730	645
	250	14.4	9.0	705	535		250	16.8	9.0	785	655
	300	14.4	9.6	760	540		300	16.8	9.6	840	660
	350	14.4	10.2	815	550		350	16.8	10.2	895	670
	400	14.4	10.8	870	555		400	16.8	10.8	950	675
	450	14.4	11.4	925	565		450	16.8	11.4	1005	685
	500	14.4	12.0	980	570		500	16.8	12.0	1060	690
	600	14.4	13.2	1200	585		600	16.8	13.2	1500	705
700	14.4	14.4	1200	600	700	16.8	14.4	1500	720		
						800	16.8	15.6	1500	735	
						900	16.8	16.8	1500	750	

➔ All Flanged Tees

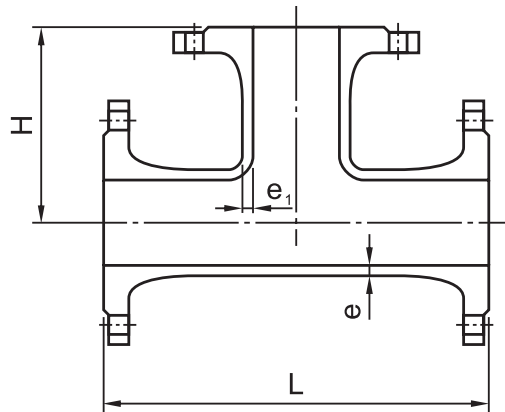

Unit : mm

Nominal size		e	e <sub>1</sub>	L	H
Body DN	Branch dn				
1000	150	18.0	7.8	715	700
	200	18.0	8.4	770	705
	250	18.0	9.0	825	715
	300	18.0	9.6	880	720
	350	18.0	10.2	935	730
	400	18.0	10.8	990	735
	450	18.0	11.4	1045	745
	500	18.0	12.0	1100	750
	600	18.0	13.2	1650	765
	700	18.0	14.4	1650	780
	800	18.0	15.6	1650	795
900	18.0	16.8	1650	810	
1000	18.0	18.0	1650	825	
1100	150	19.2	7.8	690	760
	200	19.2	8.4	750	765
	250	19.2	9.0	805	775
	300	19.2	9.6	865	780
	350	19.2	10.2	920	790
	400	19.2	10.8	980	795
	450	19.2	11.4	1040	805
	500	19.2	12.0	1095	810
	600	19.2	13.2	1210	825
	700	19.2	14.4	1330	840
	800	19.2	15.6	1445	855
900	19.2	16.8	1560	870	
1000	19.2	18.0	1675	885	
1100	19.2	19.2	1790	900	

Unit : mm

Nominal size		e	e <sub>1</sub>	L	H
Body DN	Branch dn				
1200	150	20.4	7.8	715	820
	200	20.4	8.4	775	825
	250	20.4	9.0	830	835
	300	20.4	9.6	890	840
	350	20.4	10.2	950	850
	400	20.4	10.8	1005	855
	450	20.4	11.4	1065	865
	500	20.4	12.0	1120	870
	600	20.4	13.2	1240	885
	700	20.4	14.4	1355	900
	800	20.4	15.6	1470	915
	900	20.4	16.8	1585	930
1000	20.4	18.0	1700	945	
1100	20.4	19.2	1820	960	
1200	20.4	20.4	1935	975	

➔ Double-Socket Tapers

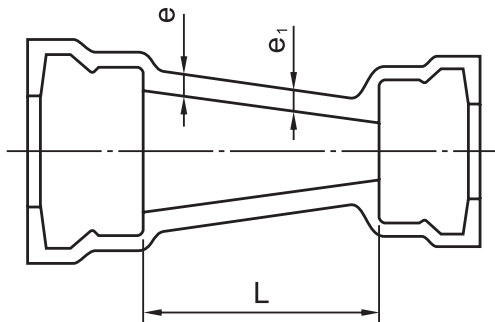

Unit : mm

Nominal size		e	e <sub>1</sub>	L
Large DN	Small dn			
100	80	7.2	7.0	90
150	80	7.8	7.0	190
	100	7.8	7.2	150
200	100	8.4	7.2	250
	150	8.4	7.8	150
250	150	9.0	7.8	250
	200	9.0	8.4	150
300	150	9.6	7.8	350
	200	9.6	8.4	250
	250	9.6	9.0	150
350	200	10.2	8.4	360
	250	10.2	9.0	260
	300	10.2	9.6	160
400	200	10.8	8.4	460
	250	10.8	9.0	360
	300	10.8	9.6	260
450	250	11.4	9.0	460
	300	11.4	9.6	360
	350	11.4	10.2	260
500	400	11.4	10.8	160
	250	12.0	9.0	560
	300	12.0	9.6	460
600	350	12.0	10.2	360
	400	12.0	10.8	260
	450	12.0	11.4	160
	300	13.2	9.6	660
	350	13.2	10.2	560

Unit : mm

Nominal size		e	e <sub>1</sub>	L
Large DN	Small dn			
700	350	14.4	10.2	800
	400	14.4	10.8	700
	450	14.4	11.4	600
	500	14.4	12.0	480
800	600	14.4	13.2	280
	400	15.6	10.8	870
	450	15.6	11.4	770
	500	15.6	12.0	670
900	600	15.6	13.2	480
	700	15.6	14.4	280
	450	16.8	11.4	940
	500	16.8	12.0	840
1000	600	16.8	13.2	640
	700	16.8	14.4	480
	800	16.8	15.6	280
	500	18.0	12.0	1040
1100	600	18.0	13.2	840
	700	18.0	14.4	680
	800	18.0	15.6	480
	900	18.0	16.8	280
1200	600	19.2	13.2	1020
	700	19.2	14.4	870
	800	19.2	15.6	670
	900	19.2	16.8	480
	1000	19.2	18.0	280
1400	1000	20.4	13.2	1220
	700	20.4	14.4	1020
	800	20.4	15.6	870
	900	20.4	16.8	670
	1000	20.4	18.0	480
1600	1100	20.4	19.2	300
	1000	22.8	18.0	560
	1100	22.8	19.2	460
1600	1200	22.8	20.4	360
	1000	25.2	18.0	760
	1100	25.2	19.2	660
	1200	25.2	20.4	560
1400	25.2	22.8	360	

➔ Flanges

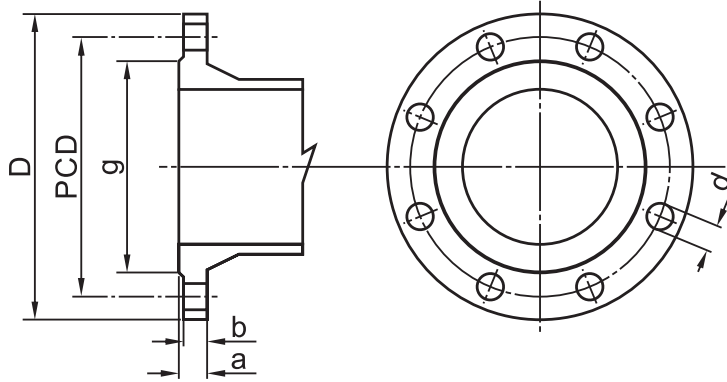

Unit : mm

Nominal size	PN 10							PN 16							
	D	g	a	b	Holes			D	g	a	b	Holes			
					PCD	No.	d					PCD	No.	d	
DN															
80	200	132	19.0	16.0	160	8	19	200	132	19.0	16.0	160	8	19	
100	220	156	19.0	16.0	180	8	19	220	156	19.0	16.0	180	8	19	
150	285	211	19.0	16.0	240	8	23	285	211	19.0	16.0	240	8	23	
200	340	266	20.0	17.0	295	8	23	340	266	20.0	17.0	295	12	23	
250	400	319	22.0	19.0	350	12	23	400	319	22.0	19.0	355	12	28	
300	455	370	24.5	20.5	400	12	23	455	370	24.5	20.5	410	12	28	
350	505	429	24.5	20.5	460	16	23	520	429	26.5	22.5	470	16	28	
400	565	480	24.5	20.5	515	16	28	580	480	28.0	24.0	525	16	31	
450	615	527	25.5	21.5	565	20	28	640	544	30.0	26.0	585	20	31	
500	670	582	26.5	22.5	620	20	28	715	609	31.5	27.5	650	20	34	
600	780	682	30.0	25.0	725	20	31	840	720	36.0	31.0	770	20	37	
700	895	794	32.5	27.5	840	24	31	910	794	39.5	34.5	840	24	37	
800	1015	901	35.0	30.0	950	24	34	1025	901	43.0	38.0	950	24	40	
900	1115	1001	37.5	32.5	1050	28	34	1125	1001	46.5	41.5	1050	28	40	
1000	1230	1112	40.0	35.0	1160	28	37	1255	1112	50.0	45.0	1170	28	43	
1100	1340	1221	42.5	37.5	1270	32	37	1355	1215	53.5	48.5	1270	32	43	
1200	1455	1328	45.0	40.0	1380	32	40	1485	1328	57.0	52.0	1390	32	49	
1400	1675	1530	46.0	41.0	1590	36	43	1685	1530	60.0	55.0	1590	36	49	
1600	1915	1750	49.0	44.0	1820	40	49	1930	1750	65.0	60.0	1820	40	56	

Unit : mm

Nominal size	PN 25							PN 40							
	D	g	a	b	Holes			D	g	a	b	Holes			
					PCD	No.	d					PCD	No.	d	
DN															
80	200	132	19.0	16.0	160	8	19	200	132	19.0	16.0	160	8	19	
100	235	156	19.0	16.0	190	8	23	235	156	19.0	16.0	190	8	23	
150	300	211	20.0	17.0	250	8	28	300	211	26.0	23.0	250	8	28	
200	360	274	22.0	19.0	310	12	28	375	284	30.0	27.0	320	12	31	
250	425	330	24.5	21.5	370	12	31	450	345	34.5	31.0	385	12	34	
300	485	389	27.5	23.5	430	16	31	515	409	39.5	35.5	450	16	34	
350	555	448	30.0	26.0	490	16	34								
400	620	503	32.0	28.0	550	16	37								
450	670	553	34.5	30.5	600	20	37								
500	730	609	36.5	32.5	660	20	37								
600	845	720	42.0	37.0	770	20	40								
700	960	820	46.5	41.5	875	24	43								
800	1085	928	51.0	46.0	990	24	49								
900	1185	1028	55.5	50.5	1090	28	49								
1000	1320	1140	60.0	55.0	1210	28	56								
1100	1420	1240	64.5	59.5	1310	32	56								
1200	1530	1350	69.0	64.0	1420	32	56								

### ➔ Double Flanged 90° Bends

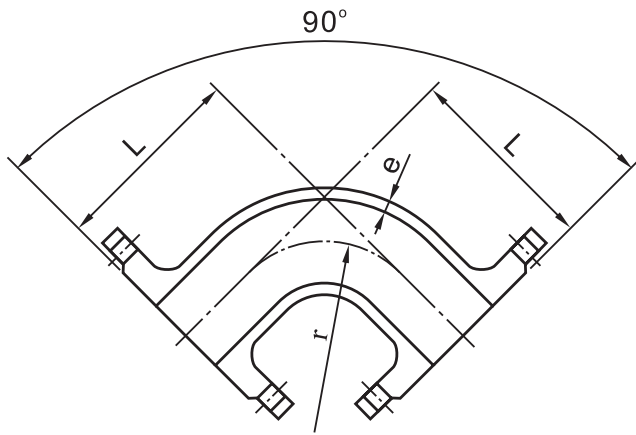

Unit : mm

Nominal size DN	e	L	r approx.
80	7.0	165	115
100	7.2	180	120
150	7.8	220	155
200	8.4	260	190
250	9.0	350	275
300	9.6	400	315
350	10.2	450	360
400	10.8	500	405
450	11.4	550	450
500	12.0	600	490
600	13.2	700	580
700	14.4	800	685
800	15.6	900	785
900	16.8	1000	875
1000	18.0	1100	965
1100	19.2	1200	1055
1200	20.4	1300	1145

### ➔ Double Flanged 45° Bends

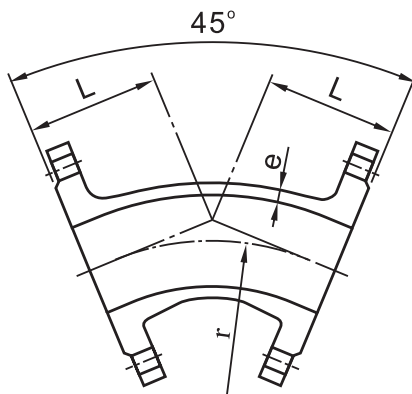

Unit : mm

Nominal size DN	e	L	r approx.
80	7.0	130	190
100	7.2	140	200
150	7.8	160	230
200	8.4	180	265
250	9.0	350	660
300	9.6	400	765
350	10.2	300	505
400	10.8	325	550
450	11.4	350	595
500	12.0	375	645
600	13.2	425	735
700	14.4	480	875
800	15.6	530	1000
900	16.8	580	1100
1000	18.0	630	1200
1100	19.2	695	1300
1200	20.4	750	1400
1400	22.8	775	1595
1600	25.2	845	1800

### ➔ Double Flanged 22.5° Bends

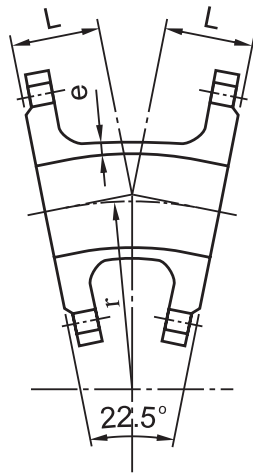

Unit : mm

Nominal size DN	e	L	r approx.
80	7.0	130	395
100	7.2	140	410
150	7.8	160	480
200	8.4	180	555
250	9.0	350	1370
300	9.6	400	1595
350	10.2	298	1050
400	10.8	324	1145
450	11.4	349	1240
500	12.0	375	1340
600	13.2	426	1535
700	14.4	478	1825
800	15.6	529	2080
900	16.8	581	2295
1000	18.0	632	2500
1100	19.2	600	2290
1200	20.4	652	2500
1400	22.8	835	3320
1600	25.2	940	3745

### ➔ Double Flanged 11.25° Bends

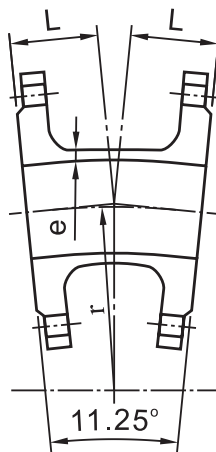

Unit : mm

Nominal size DN	e	L	r approx.
80	7.0	130	800
100	7.2	140	830
150	7.8	160	975
200	8.4	180	1115
250	9.0	350	2770
300	9.6	400	3220
350	10.2	298	2120
400	10.8	324	2315
450	11.4	349	2505
500	12.0	375	2710
600	13.2	426	3095
700	14.4	478	3685
800	15.6	529	4200
900	16.8	581	4625
1000	18.0	632	5045
1100	19.2	683	5460
1200	20.4	735	5890
1400	22.8	835	6700
1600	25.2	940	7565



## ➔ Double Flanged Tapers

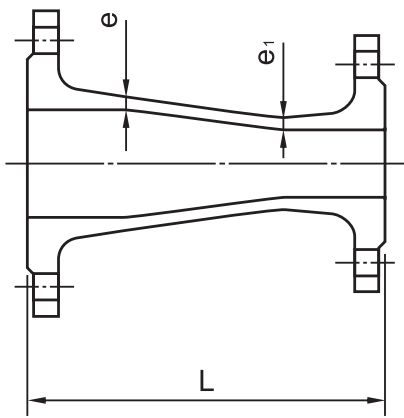

● Concentric Taper

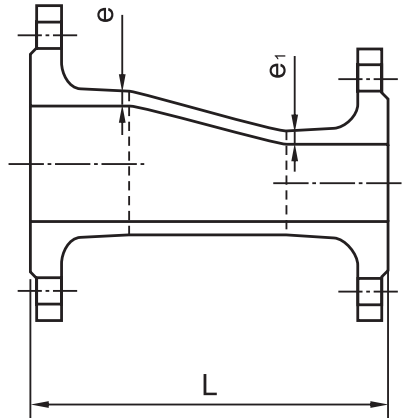

● Eccentric (Flat) Taper

Unit : mm

Nominal size		e	e <sub>1</sub>	L
Large DN	Small dn			
100	80	7.2	7.0	200
150	80	7.8	7.0	400
	100	7.8	7.2	300
200	100	8.4	7.2	600
	150	8.4	7.8	300
250	150	9.0	7.8	600
	200	9.0	8.4	300
300	150	9.6	7.8	600
	200	9.6	8.4	600
	250	9.6	9.0	300
350	200	10.2	8.4	600
	250	10.2	9.0	600
	300	10.2	9.6	300
400	200	10.8	8.4	600
	300	10.8	9.6	600
	350	10.8	10.2	300
	450	11.4	9.0	600
450	250	11.4	9.6	600
	300	11.4	10.2	600
	350	11.4	10.8	300
	500	12.0	9.0	700
500	300	12.0	9.6	600
	350	12.0	10.2	600
	400	12.0	10.8	600
	450	12.0	11.4	300
	600	13.2	9.6	800
600	350	13.2	10.2	700
	400	13.2	10.8	600
	450	13.2	11.4	600
	500	13.2	12.0	600
	700	14.4	10.2	900
700	400	14.4	10.8	800
	450	14.4	11.4	700
	500	14.4	12.0	600
	600	14.4	13.2	600

Unit : mm

Nominal size		e	e <sub>1</sub>	L
Large DN	Small dn			
800	400	15.6	10.8	1000
	450	15.6	11.4	900
	500	15.6	12.0	800
	600	15.6	13.2	600
	700	15.6	14.4	600
900	450	16.8	11.4	1100
	500	16.8	12.0	1000
	600	16.8	13.2	800
	700	16.8	14.4	600
	800	16.8	15.6	600
1000	500	18.0	12.0	1200
	600	18.0	13.2	1000
	700	18.0	14.4	800
	800	18.0	15.6	600
	900	18.0	16.8	600
1100	600	19.2	13.2	1230
	700	19.2	14.4	1050
	800	19.2	15.6	860
	900	19.2	16.8	800
	1000	19.2	18.0	600
1200	600	20.4	13.2	1450
	700	20.4	14.4	1260
	800	20.4	15.6	1070
	900	20.4	16.8	880
	1000	20.4	18.0	790
1400	1100	20.4	19.2	600
	1000	22.8	18.0	1500
	1100	22.8	19.2	1250
	1200	22.8	20.4	850
1600	1000	25.2	18.0	2000
	1100	25.2	19.2	1750
	1200	25.2	20.4	1500
	1400	25.2	22.8	910

### ➔ Double Flanged 90° Duckfoot Bends

Unit : mm

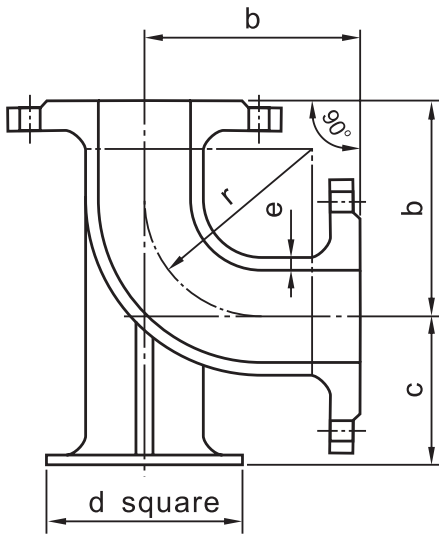

Nominal size DN	e	d	r approx.	b	c
80	7.0	180	115	165	110
100	7.2	200	120	180	125
150	7.8	250	155	220	160
200	8.4	300	190	260	190
250	9.0	350	275	350	225
300	9.6	400	315	400	255
350	10.2	450	360	450	290
400	10.8	500	405	500	320
450	11.4	550	450	550	355
500	12.0	600	490	600	385
600	13.2	700	580	700	450
700	14.4	800	685	800	515
800	15.6	900	785	900	580
900	16.8	1000	875	1000	645
1000	18.0	1100	965	1100	710
1100	19.2	1200	1055	1200	775
1200	20.4	1300	1145	1300	840

### ➔ Flange Bellmouths

Unit : mm

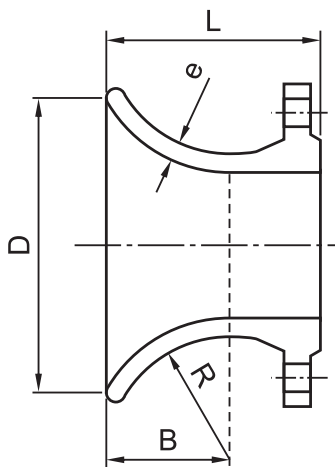

Nominal size DN		L	D	B	R
80	7.0	135	160	80	100
100	7.2	140	185	85	106
150	7.8	155	245	95	119
200	8.4	170	310	110	137
250	9.0	190	370	120	150
300	9.6	210	435	135	169
350	10.2	225	495	145	181
400	10.8	245	560	160	200
450	11.4	260	620	170	212
500	12.0	280	685	185	231
600	13.2	300	810	210	262
700	14.4	340	945	225	281
800	15.6	380	1055	240	300
900	16.8	420	1165	255	319
1000	18.0	440	1290	270	337
1100	19.2	465	1400	285	357
1200	20.4	490	1515	300	376
1400	22.8	515	1725	305	400
1600	25.2	540	1945	310	400

### ➔ Flanged Spigots

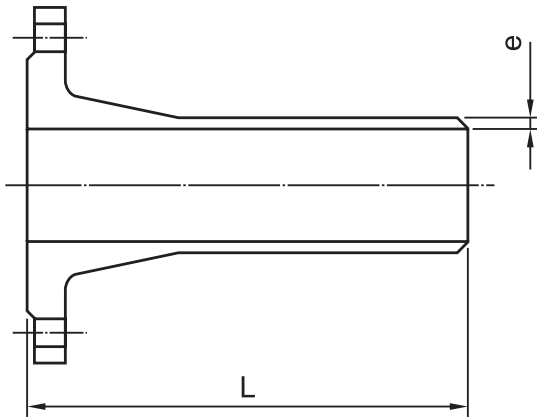

Unit : mm

Nominal size DN	e	L
80	7.0	350
100	7.2	360
150	7.8	380
200	8.4	400
250	9.0	420
300	9.6	440
350	10.2	460
400	10.8	480
450	11.4	500
500	12.0	520
600	13.2	560
700	14.4	600
800	15.6	600
900	16.8	600
1000	18.0	600
1100	19.2	600
1200	20.4	600
1400	22.8	710
1600	25.2	780

### ➔ Flanged Sockets

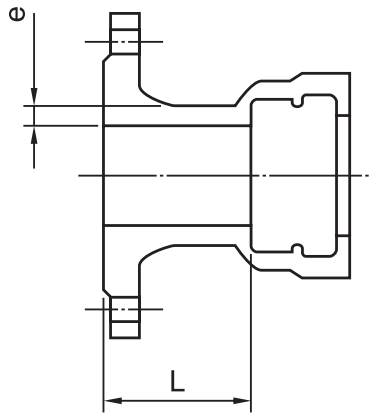

Unit : mm

Nominal size DN	e	L
80	7.0	130
100	7.2	130
150	7.8	135
200	8.4	140
250	9.0	145
300	9.6	150
350	10.2	155
400	10.8	160
450	11.4	165
500	12.0	170
600	13.2	180
700	14.4	190
800	15.6	200
900	16.8	210
1000	18.0	220
1100	19.2	230
1200	20.4	240
1400	22.8	310
1600	25.2	330

Blank Flanges

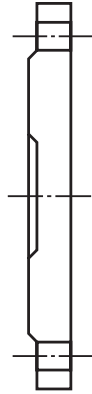

Unit : mm

Nominal size DN	Mass (Kg)		
	PN 10	PN 16	PN 25
80	3.5	3.5	3.5
100	4.3	4.3	4.8
150	7.2	7.2	8.3
200	11.0	10.8	13.3
250	16.9	16.6	21.0
300	24.0	23.5	30.0
350	30.5	34.5	44.5
400	37.5	46.0	59.5
450	46.5	63.5	80.5
500	58.0	79.5	97.0
600	88.5	125.0	149.0
700	128.0	163.0	215.0
800	180.0	228.0	304.0
900	234.0	299.0	397.0
1000	307.0	405.0	535.0
1100	391.0	518.0	670.0
1200	491.0	635.0	843.0
1400	739.0	993.0	1196.0
1600	1239.0	1462.0	1668.0

➔ Caps

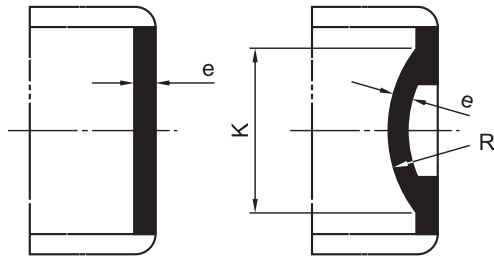

• Up to & including DN 300

• Over DN 300

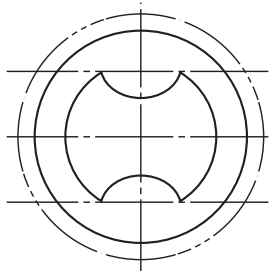

Unit : mm

Nominal size DN	e	K & R	Mass (Kg)
80	18.0	-	6.2
100	18.0	-	7.0
150	18.0	-	11.3
200	18.0	-	16.1
250	19.5	-	22.5
300	23.0	-	38.0
350	24.0	315	54.0
400	25.0	370	68.5
450	26.0	420	83.5
500	27.0	460	96.0
600	29.5	565	117.0
700	31.0	665	170.0
800	33.0	760	225.0
900	35.0	860	300.0
1000	37.0	960	370.0
1100	39.0	1060	470.0
1200	41.0	1160	580.0

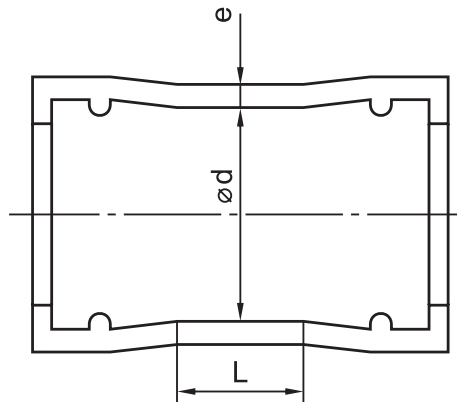

Unit : mm

Nominal size DN	e	d	L
80	7.0	109	160
100	7.2	130	160
150	7.8	183	165
200	8.4	235	170
250	9.0	288	175
300	9.6	340	180
350	10.2	393	185
400	10.8	445	190
500	12.0	550	200
600	13.2	655	210
700	14.4	760	220
800	15.6	865	230
900	16.8	970	240
1000	18.0	1075	250
1200	20.4	1285	270
1400	22.8	1477	340
1600	25.2	1683	360
1800	27.6	1889	380
2000	30.0	2095	400

## Pipe Jointing & Assembly

The Push On (Tyton) Joint pipe has long been regarded as the benchmark for rubber ring jointing systems for the water industry. Its unique design offers quick and effective assembly under all conditions.

Jointing instruction for Push On Joint Pipes.

### ○ Insertion of Gasket

The gasket should be wiped clean, flexed as shown, and then placed in the socket with bulb leading. When inserting gaskets, flexing in two places may be necessary. The groove in the gasket must be located on the retaining bead in the socket, and the retaining heel of the gasket firmly bedded in its seat so that the heel of the gasket is not proud of the mouth of the pipe.

### ○ Lubrication

A thin film of lubricant is applied on the inside surface of the gasket which will be in contact with the entering spigot, while a thin film of lubricant should be applied to the chamfer and pipe's spigot. Use only lubricant supplied by the pipe manufacturer.

#### 1. Clean of socket



#### 2. Clean of gasket



#### 3. Mounting of gasket

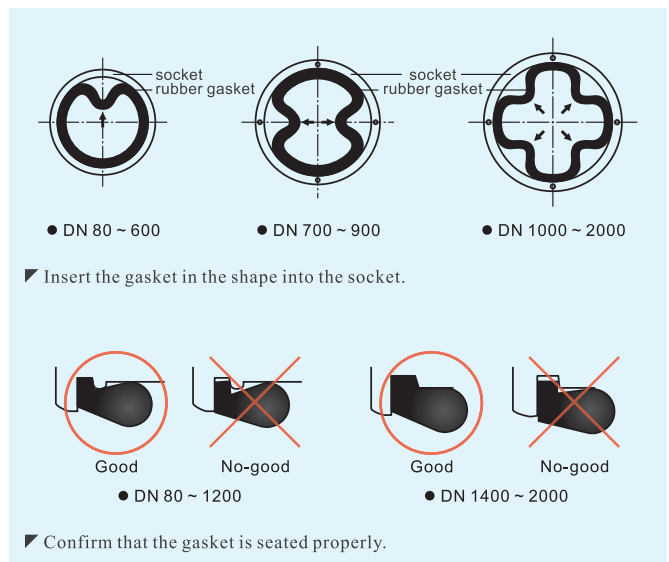

#### 4. Cleaning of spigot



#### 5. Application of lubricant

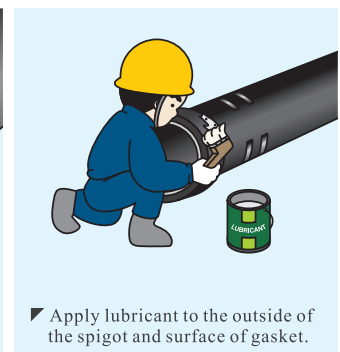

### 6. Setting of spigot-end

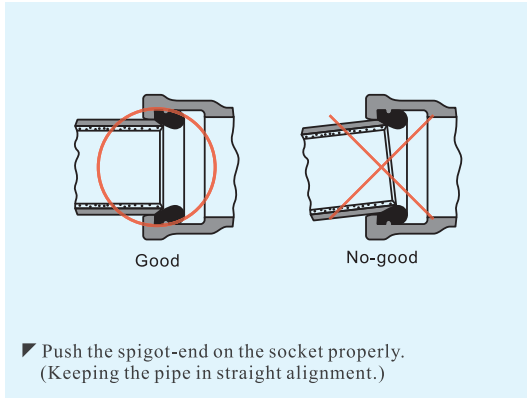

### 7. Joint of pipes

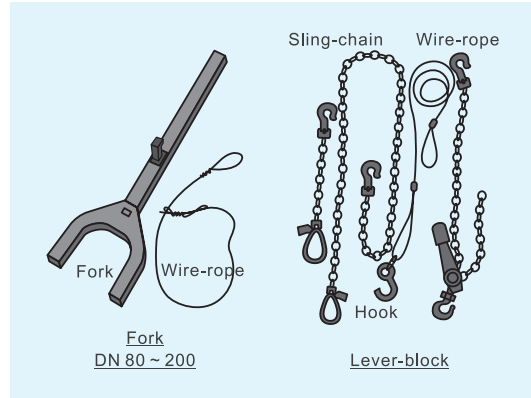

### 8. Checking of joint-condition

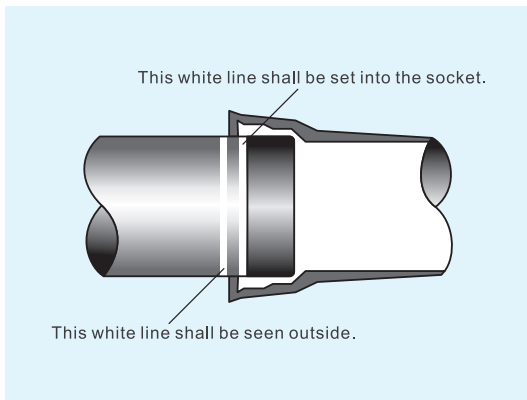

### 9. Checking of gasket

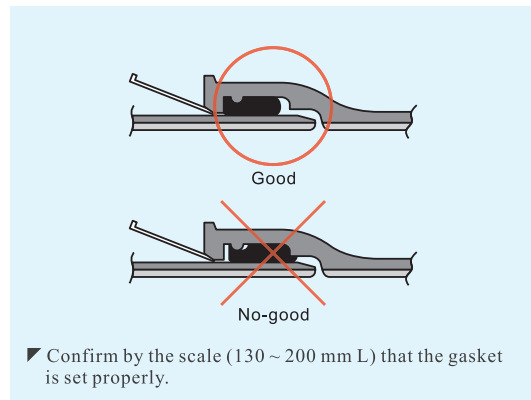

### 10. Pipe-laying

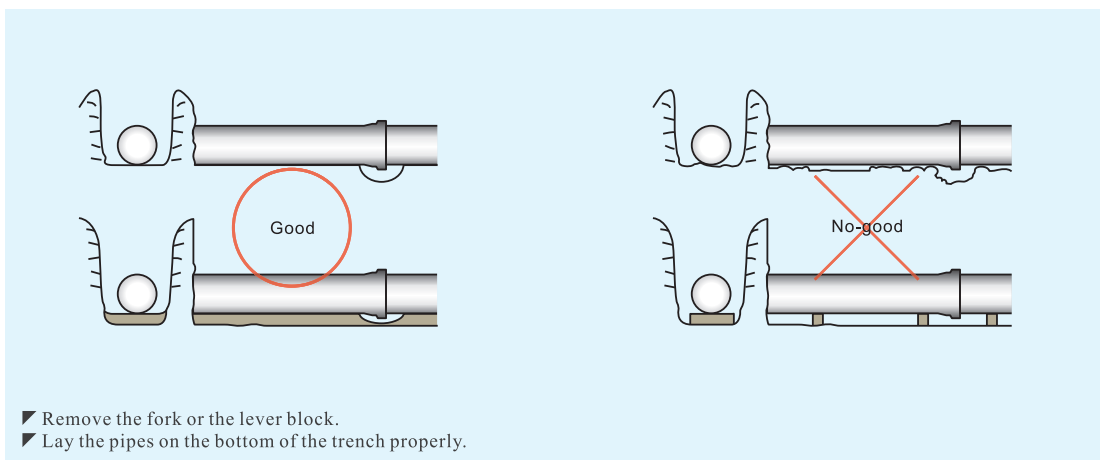



## Jointing of Cut Pipes

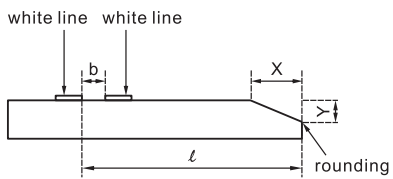
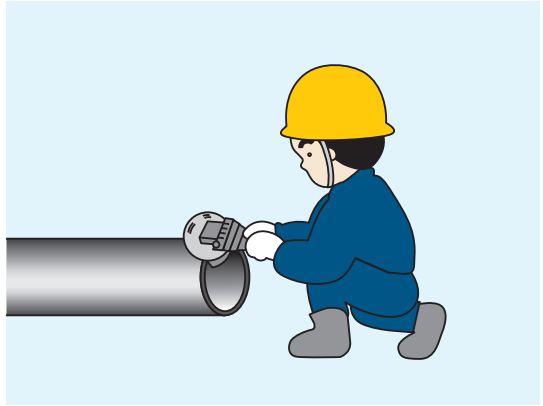
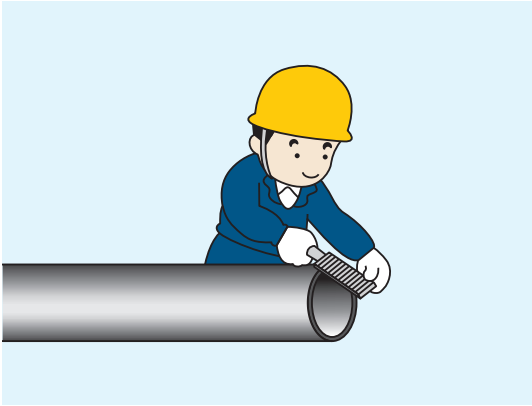

Dimensions in mm

Nominal diameter	Chamfering dimensions		Position of white line	
	X	Y	l	b
80	9	3.0	78	13
100	9	3.0	82	13
150	9	3.0	93	13
200	9	3.0	108	13
250	9	3.0	113	13
300	9	3.0	118	13
350	14	5.0	130	13
400	14	5.0	130	13
450	14	5.0	130	13
500	14	5.0	140	13
600	14	5.0	145	13
700	15	6.0	160	20
800	15	6.0	165	20
900	15	6.0	180	20
1000	19	7.5	190	20
1100	19	7.5	205	20
1200	19	7.5	220	20
1400	23	8.5	250	20
1500	23	8.5	265	20
1600	23	8.5	280	20
1800	26	9.5	310	20
2000	26	9.5	340	20

## Pipe Handling Recommendations

Ductile Iron Pipes are not susceptible to breakage by impact loading, but bad handling can result in damages to linings and in severe situation to bruising and deformation of the spigot which could affect the sealing of the joint when install.

Damage to pipes and joint components may be caused by the following:

1. Insecure loading on truck or vehicle
2. Improper use of handling equipments
3. Incorrect stacking or storing methods
4. Improper storing of jointing components
5. Unloading on uneven or sloping ground

Damage can be avoided by paying attention to the following points:

### ○ Transportation

All pipes must be secured with steel wire rope to the truck to prevent movement during transport. Suitable protection such as rubber or carpet should be placed between the wire rope and the outer pipes of the top row.

The use of straight sided loading allows full advantage to be taken of the carrying capacity of the vehicle. Pipes should be loaded onto vehicles using scalloped hardwood timbers of sufficient thickness to ensure no metal to metal contact occurs between rows of pipes.

### › Inspection

On receipt of pipes, it should be inspected of damages to:

- a. The Pipe itself
- b. Cement mortar linings
- c. Jointing surfaces (Socket area)

And proposed remedial work shall be undertaken (whenever require) as soon as possible.

### ○ Unloading

#### › Offloading by Crane

Pipe masses, type of stacking, outreach required and the site conditions are the important factors to take into account when determining the suitability of lifting equipment. The machine used must be of the type which retains the load safely in the event of a power failure.

#### › Lifting Operation

It is necessary when using mechanical handling equipment to employ experienced and qualified personnel to carry out the operation efficiently and safely.

Where the crane operator does not have a clear view of the load, he should be guided by the person supervising the operation. The pipes should be lifted smoothly, without sudden jerking motions, and pipe movement should be controlled by the use of guide ropes. This is necessary for safety and also to prevent damage caused by pipes bumping together or against surrounding objects.

Lifting and placing must be carried out in such a way that the stability of the stack, crane or vehicle is not affected. Steel wire rope securing the pipes to the truck should not be released before ensuring the truck is positioned on level ground.

## Pipe Installation & Joint Assembly Method

Pipe installation and assembly of joint is easy and quick, may depend on pipes sizes and local conditions to be carried out by the following applications:

### ○ Crowbar System

Complete entry of the spigot into the socket may be obtained by pushing with a crowbar or suitable lever against the face of the socket of the entering pipe.

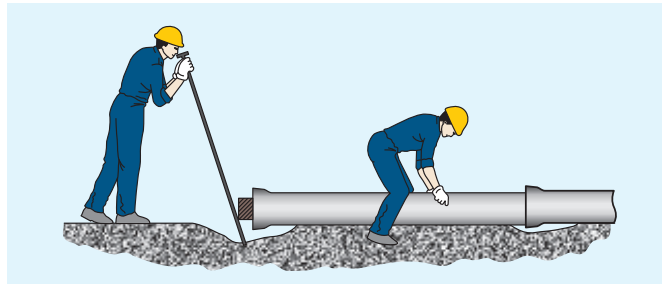

### ○ Trifor System

For pipes diameter larger than DN 150mm, a wire rope or chain puller can be used as shown in the drawing. This puller device is available as Trifor system.

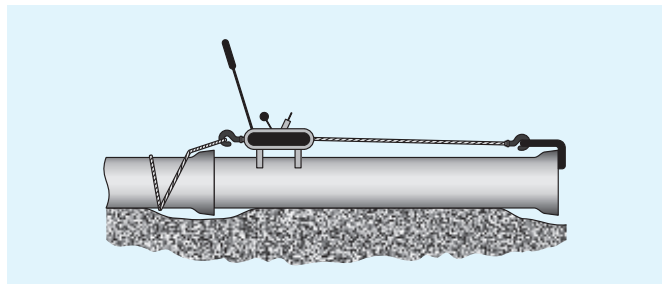

### ○ Trench Excavator System

Where the trench is being prepared by using a backhoe or excavator, either machine may be used to push the spigot into its position. This system is mainly used on large diameter pipe and a timber header should be placed between the pipe and the bucket to prevent damage to the pipe.

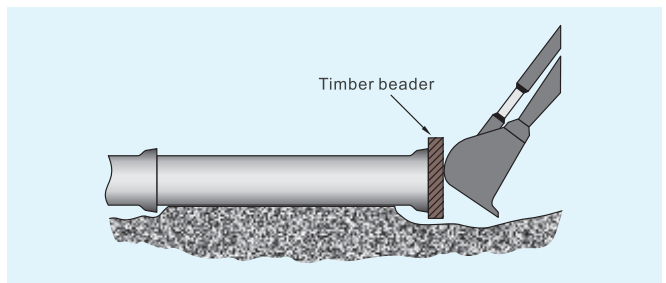

### ○ Hairpin Lifting System

A hairpin lifting mandrel may be utilized for both lifting the pipe and making the joint assembly. The mandrel is inserted into the bore of the pipe as shown, make sure care should be taken not to damage the internal cement lining of the inner coating of the pipe surface. The pipe can be lifted and placed into the trench and jointed. The hairpin may also be used for the pipes sleeving wrapping up prior to laying and jointing at the trench.

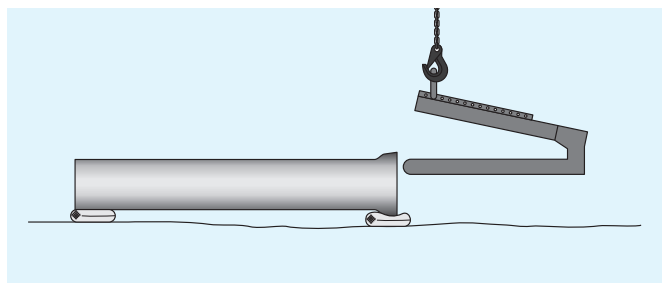

## Corrosion Protection

### ○ Polyethylene Sleeves

Polyethylene sleeves use for ductile iron pipelines is intended to prevent surrounding aggressive soils/groundwater contacting the pipeline and causing corrosion. Condensate or small amounts of water trapped within the sleeve are not of concern. Free flow of ground water within the sleeve however is unacceptable and should not be occurring in properly installed sleeve.

The PE sleeve is one piece tubular of size to easily slip over the pipes and fittings. After slipping onto the pipe of fitting, the sleeve is folded longitudinally to more tightly fit the pipe of fitting.

The sleeve is held folded by tape tightly wrapped circumferentially, at 1000 mm maximum intervals for pipe and adjacent to joints for fittings, to prevent free flow of water. Sleeve is to be serrated at 6.1 m intervals to tear easily to useable lengths.

#### > Advantages

- ✔ It is inexpensive.
- ✔ It requires no monitoring or maintenance.
- ✔ It has no operating costs.
- ✔ It will not deteriorate while in the ground.
- ✔ It is easy to install.
- ✔ It is easy to repair damages area (repaired with adhesive tapes).
- ✔ It requires no special handling or packaging when shipment of pipe.

#### > Standard

ISO 8180 Ductile Iron Pipes - Polyethylene sleeving

#### > Materials

Polyethylene or ethylene and olefin copolymers

#### > Design

- ✔ High resistance to moisture
- ✔ Moderate conformability to uneven surfaces

#### > Thickness

min. 200 µm

#### > Elongation

min. 300% in both directions

#### > Color

Black

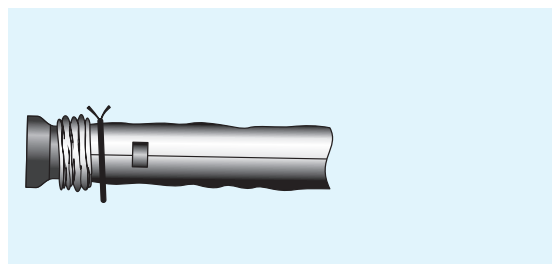
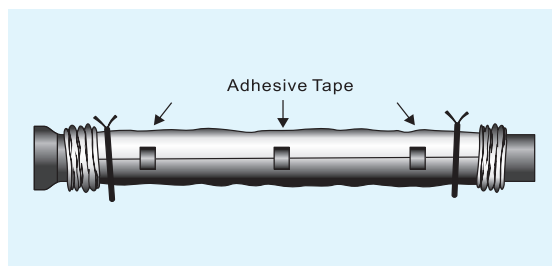
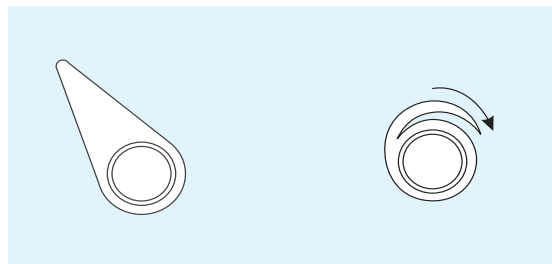
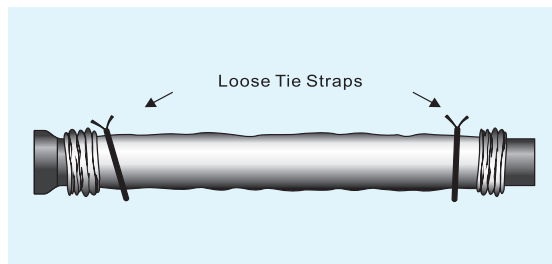
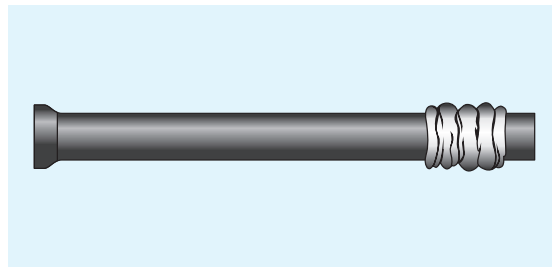

## Pipeline PE Sleeving Installation

### Guidance for the assembly of Polyethylene Sleeving to Ductile Iron Pipes.

1. Lift the pipe to the sleeving area. Check the pipe surfaces is free from any debris or adherent soil. Remove a sleeve from the roll and draw it over the spigot end of the pipe. Draw the entire sleeve onto the raised end of the pipe (socket side) bunching the sleeving in folded method towards the sling.

2. Locate the sleeve end on the line of diamonds near the spigot end. Pull the sleeving tightly around the pipe barrel, over a length of approximately 1.5m from the spigot end, and fold the surplus over to form a triple layer thickness of sleeving on top of the pipe.

Secure the sleeve end to the pipe by sealing the free edge to the pipe with three overlapping turns of tape.

Work loose sleeving toward the sling and secure the fold with tape. Lower onto sand bags and remove sling.

3. Spread the bunched sleeve towards the socket, tightly wrapped and secure the fold with tape at 1.0m intervals.

4. Lower the pipe into the excavated earth (trench) after ensuring that suitable depression has been made in the bedding at the joint position to allow the overlap to be made.

5. Locate the spigot of the pipe in the preceding socket when bedding the pipe. Remove the sling and complete assembly of the joint.

Draw the bunched sleeving from behind the socket of the preceding pipe over the joint onto the barrel of the next pipe. Care should be taken to avoid scooping backfill into the sleeving as it is pulled across the bedding depression.

Ensure the overlapping sleeving follows the contour of the joint, avoiding bridging of irregular profiles.

6. Secure the overlap to the sleeved barrel of the last pipe using steel wire strap and buckle.

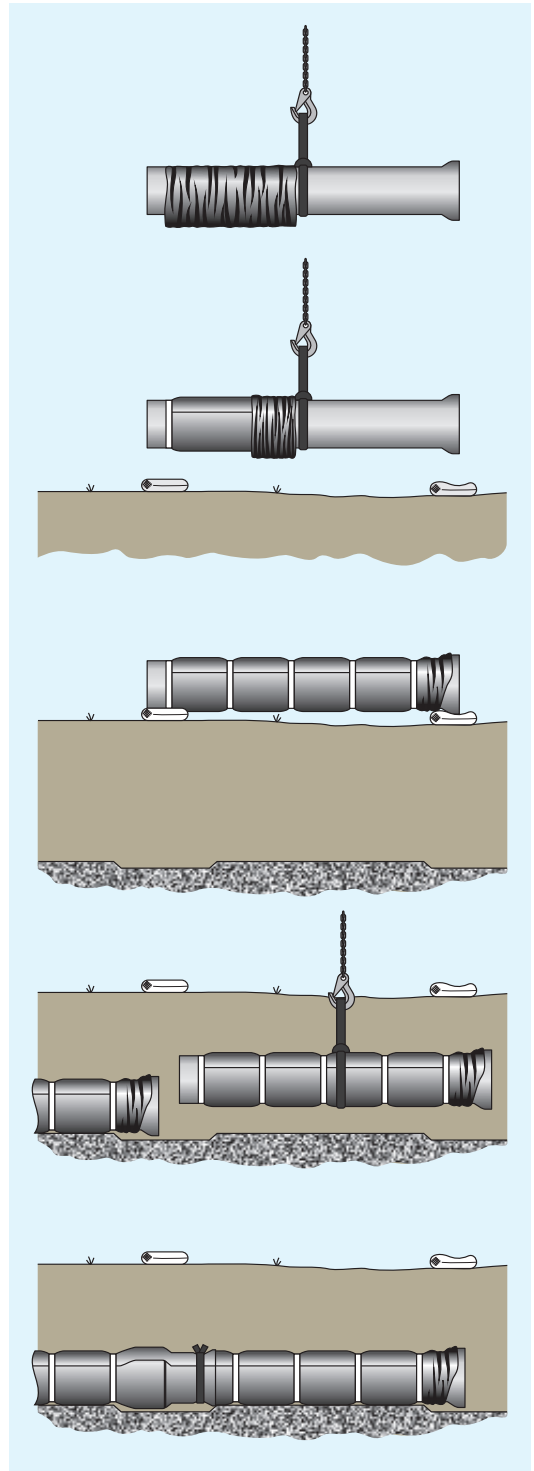



## Contact Information



[www.snpipe.com](http://www.snpipe.com)

email : [sales@snpipe.com](mailto:sales@snpipe.com)

### 總公司 | Head Office

704 台南市公園路 435 號

Tel/ +886-6-2513646 Fax/ +886-6-2514898

No.435,Kung Yuan Road, Tainan City 704, Taiwan, R.O.C.

### 台北辦事處 | Taipei Office

106 台北市大安區永康街 23 巷 19 號

Tel/ +886-2-23412580 Fax/ +886-2-23943355

No.19, Lane 23, Yung Kang St., Taipei City 106, Taiwan, R.O.C.

### 永康廠 | Yung Kang Plant

710 台南市永康區鹽洲里洲尾街 72 號

Tel/ +886-6-2534185 Fax/ +886-6-2533554

No.72, Zhouwei St., Yung Kang Dist., Tainan City 710, Taiwan (R.O.C.)

### 山上廠 | Sun Shine Plant

743 台南市山上區明和里北勢洲 90 號

Tel/ +886-6-5781940 Fax/ +886-6-5781915

No.90, Beishizhou, Shanshang Dist., Tainan City 743, Taiwan (R.O.C.)