

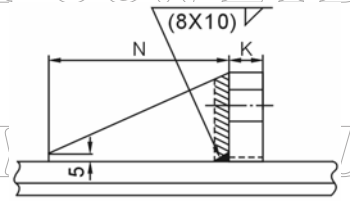

U型推進工法用延性鑄鐵管

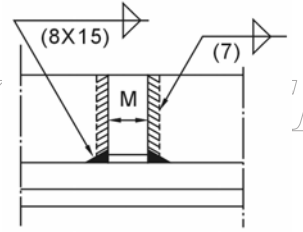
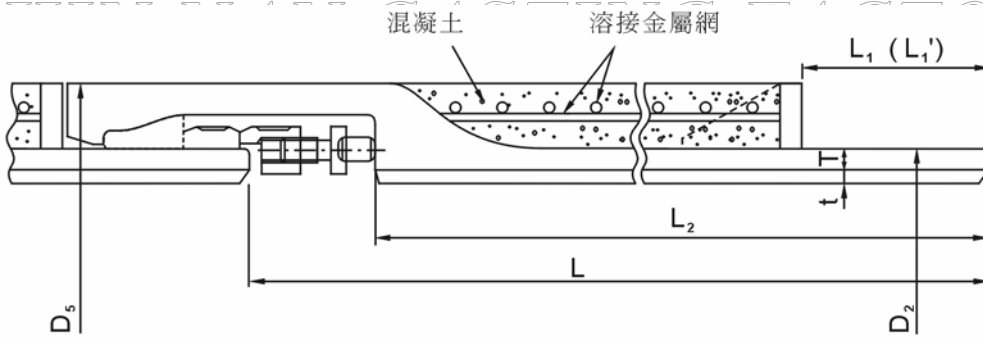

單位：mm

標稱管徑	管 厚									內襯厚度	有效長度	各 部 尺 度									
	T											t	L	D ₂	D ₅	L ₁	L ₂	M	N	K	L ₁ '
	D1	D1.5	D2	D2.5	D3	D3.5	D4	D4.5	D5												
800	13.5	-	12.0	-	11.0	-	10.0	-	9.0	6.0	6000	836	938	160	5895	19	140	19	360		
900	15.0	-	13.0	-	12.0	-	11.0	-	9.5	6.0	6000	939	1043	160	5895	19	140	19	360		
1000	16.5	-	14.5	-	13.0	-	12.0	-	10.5	6.0	6000	1041	1151	165	5895	25	140	25	380		
1100	18.0	-	15.5	-	14.0	-	13.0	-	11.0	6.0	6000	1144	1258	165	5895	25	140	25	380		
1200	19.5	-	17.0	-	15.0	-	13.5	-	11.5	6.0	6000	1246	1362	165	5895	25	140	25	380		
1350	21.5	-	18.5	-	16.5	-	15.0	-	12.5	9.0	6000	1400	1521	175	5895	25	140	25	420		
1500	23.5	-	20.5	-	18.0	-	16.5	-	14.0	9.0	6000	1554	1679	180	5895	28	150	28	420		
1600	25.0	23.5	22.0	20.5	19.0	18.0	17.5	16.0	14.5	9.0	4000	1650	1786	180	3885	28	150	28	440		
										5000	4885										
1650	25.5	24.0	22.5	21.0	19.5	18.5	18.0	16.5	15.0	9.0	4000	1701	1839	180	3885	28	150	28	440		
										5000	4885										
1800	28.0	26.0	24.0	22.5	21.0	20.0	19.5	18.0	16.0	9.0	4000	1848	1990	180	3885	28	150	28	480		
										5000	4885										
2000	30.5	28.5	26.5	25.0	23.5	22.0	21.0	19.5	18.0	9.0	4000	2061	2209	185	3885	32	160	32	530		
										5000	4885										

備考：L₁'為先頭管尺寸。

SHIN NAN CASTING FACTORY CO., LTD.
 SHIN NAN CASTING FACTORY CO., LTD.
 SHIN NAN CASTING FACTORY CO., LTD.
 SHIN NAN CASTING FACTORY CO., LTD.