

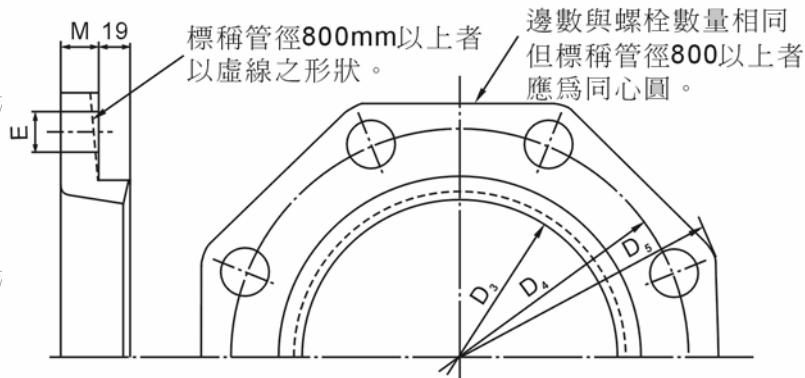

●K型用接合配件 - 壓圈



單位：mm

標稱管徑	各部尺度					螺栓數量	質量 (kg)
	D ₃	D ₄	D ₅	E	M		
100	122.0	186	232	23	16	4	2.49
150	173.0	241	287	23	17	6	4.27
200	224.0	292	338	23	18	6	5.31
250	275.6	348	394	23	19	8	7.53
300	326.8	399	445	23	20	8	8.91
350	378.0	458	504	23	21	10	11.90
400	429.6	512	558	23	22	12	14.60
450	480.8	567	613	23	23	12	17.20
500	532.0	618	664	23	24	14	19.90
600	634.8	725	771	23	25	14	24.90
700	738.0	839	893	27	26	16	35.20
800	841.0	942	996	27	28	20	42.10
900	944.0	1052	1118	33	29	20	53.90
1000	1047.0	1160	1226	33	30	20	63.20
1100	1150.0	1266	1332	33	31	24	72.10
1200	1253.0	1372	1438	33	32	28	81.30
1350	1407.0	1536	1602	33	33	28	99.40
1500	1561.0	1700	1766	33	35	28	123.00
1600	1658.0	1790	1856	33	35	30	128.00
1650	1709.0	1844	1910	33	36	30	137.00
1800	1856.0	1996	2062	33	38	34	160.00
2000	2069.0	2216	2282	33	40	36	194.00

各部尺度之許可差

單位：mm

標稱管徑	許可差				
	D ₃	D ₄	D ₅	E ⁽¹⁾	M
100 250	+3.0 -1.0	±1.5	+不予規定 -2.0	+1.5 -0.5	+3.0
300 600					+4.0 -2.0
700 900	+5.0 -2.5				
1000 1500	+6.0 -3.0				
1600 1800	+4.5 -1.0	±2.0	+不予規定 -3.0		+7.0
2000					-3.0

註(1) 螺栓孔如為鑄孔者，單邊之許可差可至+2.5mm。