

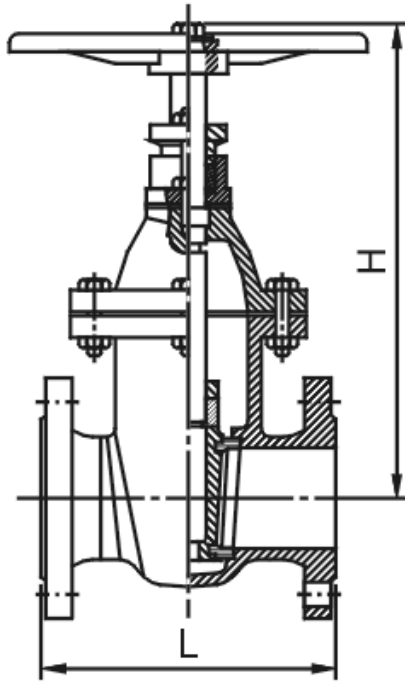

Non rising stem resilient soft seated gate valves BS 5163



Material

Body	Cast iron / Ductile iron
Bonnet	Cast iron / Ductile iron
Wedge	Cast iron / Ductile iron
Stem	Stainless steel / Brass
Body seat ring	Brass / bronze / Stainless steel
Wedge seat ring	Brass / bronze / Stainless steel

Design

Face to face is according to BS 5163 : 1986
Flange drilled is according to BS 4504

Test

Working pressure	PN 10	PN 16
Shell pressure	PN 15	PN 24
Seat pressure	PN 11	PN 17.6

Dimension

Unit: mm

Size (DN)	40	50	65	80	100	125	150	200	250	300	350	400	450	500	600
L	165	178	190	203	229	254	267	292	330	356	381	406	432	457	508
H	285	302	322	380	420	475	490	645	750	870	940	1060	1180	1300	1420
<b>Working Pressure: PN 10</b>															
Dia. of flange	150	165	185	200	220	250	285	340	395	445	505	565	615	670	780
Nos. of hole	4	4	4	4	8	8	8	8	12	12	16	16	20	20	20
Dia. of hole	18	18	18	18	18	18	22	22	22	22	22	26	26	26	30
P.C.D	110	125	145	160	180	210	240	295	350	400	460	515	565	620	725
<b>Working Pressure: PN 10</b>															
Dia. of flange	150	165	185	200	220	250	285	340	405	460	520	580	640	715	840
Nos. of hole	4	4	4	8	8	8	8	12	12	12	16	16	20	20	20
Dia. of hole	18	18	18	18	18	18	22	22	26	26	26	30	30	33	36
P.C.D	110	125	145	160	180	210	240	295	355	410	470	525	585	650	770

SHIN NAN CASTING FACTORY CO., LTD.

SHIN NAN CASTING FACTORY CO., LTD.