

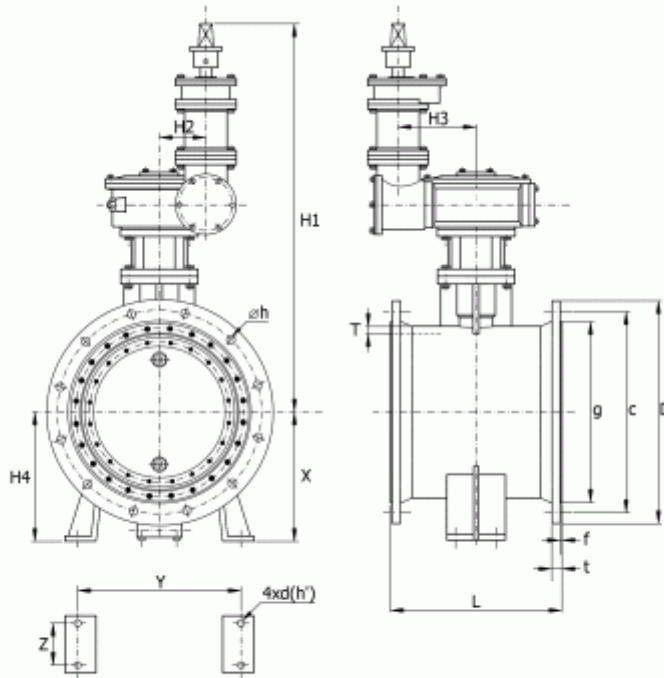

Long Body Type Butterfly Valve - Double Disc Type



長體型蝶閥-雙閥瓣立式  
Long Body Type Butterfly Valves  
(Double Disc & Vertical Type)

Unit: mm

Nom. Dia.	Flange Dimensions														Dimensions of Valve Body (min.)					Height and Length (max.)						
	Class 1 & 2							Class 3							X	Y	Z	h'	d	L	H1	H2	H3	H4		
	O.D.	O.D. of Gasket Seat	Bolt Hole		Bolt Designation	Thickness		O.D.	O.D. of Gasket Seat	Bolt Hole		Bolt Designation	Thickness													
D	g	c	h	No.		t	f	D	g	c	h		No.	t	f											
400	582	466	524	25	12	M22	27	4	560	452	510	27	16	M24	28	4	400	400	150	20	M18	470	1160	146	241	350
450	652	518	585	27	12	M24	28	4	620	498	565	27	20	M24	30	4	400	450	150	20	M18	500	1200	146	241	400
500	706	572	639	27	12	M24	29	4	675	553	620	27	20	M24	30	4	400	500	150	20	M18	530	1250	146	241	450