

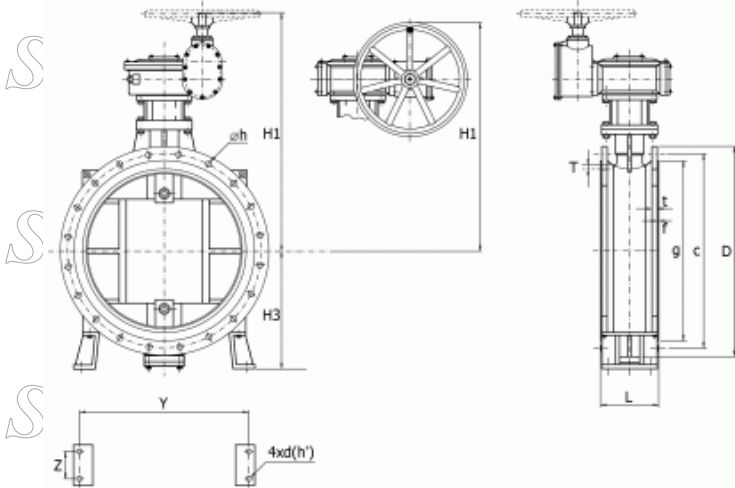

Short Body Type Butterfly Valve - Single Disc Type

SHIN NAN CASTING



■ 短體型蝶閥-單閥瓣立式  
Short Body Type Butterfly Valves  
(Single Disc & Vertical Type)

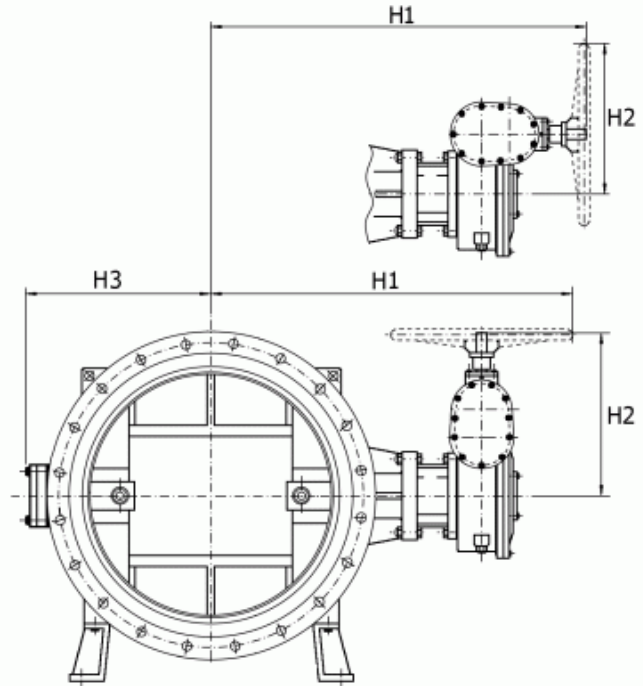

■ 短體型蝶閥-單閥瓣臥式  
Short Body Type Butterfly Valves  
(Single Disc & Horizontal Type)

Unit: mm

Nom. Dia.	Flange Dimensions													Dimensions of Valve Body (min.)				Height and Length (max.)						
	Class 1 & 2						Class 3							Y	Z	h	d'	L	H1	H2	H3			
	O.D.	O.D. of Gasket Seat	Bolt Hole		Bolt Designation	Thickness	O.D.	O.D. of Gasket Seat	Bolt Hole		Bolt Designation	Thickness												
			Dia. of Pitch Circle	h					No.	Dia. of Pitch Circle			h									No.		
D	g	c			t	f	D	g	c	h	No.	t	f											
400	582	466	524	25	12	M22	27	3	560	475	510	27	16	M24	29	3	400	150	20	M18	203	1000	550	450
450	652	518	585	27	12	M24	28	3	620	530	565	27	20	M24	30	3	450	150	20	M18	203	1000	550	500
500	706	572	639	27	12	M24	29	4	675	585	620	27	20	M24	31	3	500	150	20	M18	203	1000	550	500
600	810	676	743	27	16	M24	30	4	795	690	730	33	24	M30	32	3	600	150	23	M20	203	1100	650	600
700	928	780	854	33	16	M30	31	4	905	800	840	33	24	M30	34	3	700	220	23	M20	305	1300	700	650
800	1034	886	960	33	20	M30	32	4	1020	905	950	33	28	M30	36	3	800	220	23	M20	305	1400	750	700
900	1156	990	1073	33	20	M30	33	4	1120	1005	1050	33	28	M30	38	3	900	220	27	M24	305	1450	750	750
1000	1262	1096	1179	33	24	M30	34	4	1235	1110	1160	39	28	M36	40	3	1000	220	27	M24	305	1550	950	800
1100	1366	1200	1283	33	24	M30	36	4	1345	1220	1270	39	28	M36	42	3	1100	230	27	M24	305	1650	950	900
1200	1470	1304	1387	33	28	M30	38	4	1465	1325	1380	39	32	M36	44	3	1200	230	27	M24	381	1700	950	950
1350	1642	1462	1552	39	28	M36	40	4	1630	1480	1540	46	36	M42	48	3	1350	230	33	M30	381	1800	950	1050
1500	1800	1620	1710	39	32	M36	42	5	1795	1635	1700	46	40	M42	50	3	1500	230	33	M30	381	1900	950	1200
1650	1965	1810	1870	39	40	M36	48	5	-	-	-	-	-	-	-	-	-	-	-	-	457	2000	1000	1350
1800	2115	1960	2020	39	44	M36	49	5	-	-	-	-	-	-	-	-	-	-	-	-	457	2400	1350	1500
2000	2325	2170	2230	46	48	M42	51	5	-	-	-	-	-	-	-	-	-	-	-	-	500	2600	1450	1700
2200	2550	2370	2440	46	52	M42	54	6	-	-	-	-	-	-	-	-	-	-	-	-	580	3000	1600	1800
2400	2760	2570	2650	46	56	M42	56	6	-	-	-	-	-	-	-	-	-	-	-	-	580	3100	1700	1850